



**UNHCR**  
The UN Refugee Agency



**UNHCR  
WASH  
EQUIPMENT  
SPECIFICATIONS**



# Foreword

These WASH Equipment Specifications have been produced by UNHCR's WASH and Procurement Departments to improve the acquisition and effective procurement of WASH relief items.

This document includes specifications and quality requirements for standard WASH equipment items such as pumps, tapstands, water tanks and water testing equipment. UNHCR has established a number of international Frame Agreements for some of the items to secure an effective supply of these items. Moreover, the organization maintains a stock of some of these WASH materials in its central stockpiles in Dubai and Copenhagen to ensure their immediate delivery in emergency situations. UNHCR also has regional stocks in Accra, Republic of Ghana and in Isaka, Tanzania. Where WASH equipment is procured through other channels or locally all efforts should be made to meet the quality specifications described in this document.

This document is intended for use by all actors involved in planning and delivering humanitarian assistance to refugees and UNHCR's persons of concern. This includes UNHCR staff and external organizations such as other UN agencies, donors, national governments, manufacturers, and WASH implementing organisations.

We hope that UNHCR's WASH Equipment Specifications will be a useful tool for UNHCR operations and the humanitarian community as they endeavour to ensure the timely delivery of the highest quality of assistance to refugees and UNHCR persons of concern worldwide.

We are grateful to all UNHCR staff and technical advisors from various WASH agencies for their invaluable advice in preparing and reviewing the specifications within this catalogue. We are especially grateful to OXFAM, UNICEF, IFRC and MSF for their invaluable contribution to the standardisation of WASH emergency equipment and the authorisation to use duplicate items in their respective catalogues in the setting up of the present document.

This document will be periodically updated by the UNHCR WASH Team and will be available on the UNHCR WASH Website ([wash.unhcr.org/wash-equipment-specifications](http://wash.unhcr.org/wash-equipment-specifications)). Comments and queries about the UNHCR WASH Equipment Specifications are welcome and should be directed to [wash@unhcr.org](mailto:wash@unhcr.org).

Murray Burt  
Senior WASH Officer  
UNHCR Geneva  
December 2016

# UNHCR WASH Equipment Specifications

## Contents

<b>Foreword</b>	i
<b>Chapter 1. Water Pumping</b>	
1.1 <a href="#"><u>2" Centrifugal Diesel Surface Water Pump Kit (6 l/s @ 25m)</u></a>	1
1.2 <a href="#"><u>4" Centrifugal Diesel Surface Water Pump Kit (35 l/s @ 20m)</u></a>	2
1.3 <a href="#"><u>Hand Dug Well Dewatering Pump Kit (With 400V Generator)</u></a>	3
1.4 <a href="#"><u>3" Electric Submersible Borehole Pump Kit (5.8 m<sup>3</sup>/hr @ 60m)</u></a>	4
1.5 <a href="#"><u>4" Electric Submersible Borehole Pump Kit (8.0 m<sup>3</sup>/hr @ 107m)</u></a>	5
1.6 <a href="#"><u>3" Solar Submersible Borehole Pump Kit (2.0 m<sup>3</sup>/hr @ 40m)</u></a>	6
1.7 <a href="#"><u>4" Solar Submersible Borehole Pump Kit (4.0 m<sup>3</sup>/hr @ 70m)</u></a>	7
1.8 <a href="#"><u>Afridev Handpump (Complete Package 40m Installation)</u></a>	8
1.9 <a href="#"><u>India Mark III Handpump (Complete Package 40m Installation)</u></a>	9
<b>Chapter 2. Bulk Water Storage</b>	
2.1 <a href="#"><u>Water Bladder Kits 5m<sup>3</sup>, 10m<sup>3</sup>, 15m<sup>3</sup>, 20m<sup>3</sup> With Fittings</u></a>	11
2.2 <a href="#"><u>Trucking Bladder Kit 6m<sup>3</sup> With Fittings</u></a>	12
2.3 <a href="#"><u>Onion Tank Kits 10m<sup>3</sup> and 30m<sup>3</sup> With Fittings</u></a>	13
2.4 <a href="#"><u>Steel Tank Kits 11m<sup>3</sup>, 45m<sup>3</sup>, 70m<sup>3</sup> and 95m<sup>3</sup> With Fittings</u></a>	14
2.5 <a href="#"><u>Poly Tank Kits 5m<sup>3</sup>, 10m<sup>3</sup>, 20m<sup>3</sup>, 40m<sup>3</sup> With Fittings</u></a>	15
2.7 <a href="#"><u>Tank Fittings Kits</u></a>	16
<b>Chapter 3. Water Treatment</b>	
3.1 <a href="#"><u>Water Treatment Sachets (Flocculant/Disinfectant)</u></a>	18
3.2 <a href="#"><u>Water Disinfection Tablets (67mg and 1.67g NaDCC)</u></a>	19
3.3 <a href="#"><u>Household Ceramic Candle Filter (+ Storage Unit)</u></a>	20
3.4 <a href="#"><u>Calcium Hypochlorite HTH (450g, 5kg and 45kg)</u></a>	21
3.5 <a href="#"><u>Chlorine Dispenser (Floating Pot Type)</u></a>	22
3.6 <a href="#"><u>Chemical Doser Kit (Suction Side Doser)</u></a>	23
3.7 <a href="#"><u>Chemical Doser Kit (Proportional Doser)</u></a>	24
3.8 <a href="#"><u>Aluminium Sulphate Al<sub>2</sub>(SO<sub>4</sub>)<sub>3</sub> Granules 50kg (Min. 17% Al<sub>2</sub>O<sub>3</sub>)</u></a>	25
3.9 <a href="#"><u>Compact Water Treatment Unit (4,000 Litres/Hour)</u></a>	26
<b>Chapter 4. Water Distribution</b>	
4.1 <a href="#"><u>Tapstand Kit (Six Taps with Connections Kit and Installation Kit)</u></a>	28
4.2 <a href="#"><u>PVC Layflat Hose (2" or 3" Including Hose Couplings)</u></a>	29
4.3 <a href="#"><u>PVC Spiral Hose (2" or 3" Including Hose Couplings)</u></a>	30
4.4 <a href="#"><u>HDPE Water Distribution Pipe (32mm, 63mm, 90mm in Coils)</u></a>	31
<b>Chapter 5. Water Quality Testing</b>	
5.1 <a href="#"><u>Pooltester (pH, Free and Total Chlorine – Plus Reagents)</u></a>	33
5.2 <a href="#"><u>Microbiological Water Testing Kit (With Incubator and Battery)</u></a>	34
5.3 <a href="#"><u>EColi and Total Coliform Test Tubes (100ml x 200 Tests)</u></a>	35
5.4 <a href="#"><u>H2S Presence/Absence Field Kit (100 Tests)</u></a>	36

5.5	<a href="#"><u>Chemical Test Kit (Colour Comparator – Multiple Parameters)</u></a>	37
5.6	<a href="#"><u>Visual Arsenic Detection Kit (200 Tests)</u></a>	38
5.7	<a href="#"><u>Digital Arsenic Detection Kit (420 Tests)</u></a>	39
5.8	<a href="#"><u>Pocket Conductivity Meter (0-2000<math>\mu</math>S/cm)</u></a>	40
5.9	<a href="#"><u>Precision Digital Balance (Portable 0-2000g x 0.1g)</u></a>	41
<b>Chapter 6. Latrines / Sanitation / Solid Waste</b>		
6.1	<a href="#"><u>Plastic Self Supporting Latrine Slab (0.8m x 1.2m)</u></a>	43
6.2	<a href="#"><u>Pour Flush Inset for Plastic Squatting Slab</u></a>	44
6.3	<a href="#"><u>Family Latrine Digging Toolkit (10 Families)</u></a>	45
6.4	<a href="#"><u>Plastic Low-Volume Pour Flush Toilet Pan</u></a>	46
6.4	<a href="#"><u>Solid Waste Clearing Materials (50 Persons)</u></a>	47
6.5	<a href="#"><u>Solid Waste Collection Worker Protection Kit (50 Persons)</u></a>	48
<b>Chapter 7. Hygiene Promotion</b>		
7.1	<a href="#"><u>Basic Family WASH and Dignity Kit (5 Families)</u></a>	50
7.2	<a href="#"><u>Multi-Purpose Soap Bars 125g (Handwashing and Laundry)</u></a>	51
7.3	<a href="#"><u>Multi-Purpose (Sanitary) Absorbent Cloth</u></a>	52
7.4	<a href="#"><u>Child's Potty (Plastic)</u></a>	53
7.5	<a href="#"><u>Handheld Megaphone (20 Watts Rechargeable)</u></a>	54
7.6	<a href="#"><u>Laminator A3 (Plus Laminating Sleeves)</u></a>	55
7.7	<a href="#"><u>School Emergency Hygiene Kit</u></a>	56
<b>Chapter 8. Disease Vector Control</b>		
8.1	<a href="#"><u>General Purpose Backpack Sprayer (Plastic Tank 15l)</u></a>	58
8.2	<a href="#"><u>Sprayer for Indoor Residual Spraying (Metal Tank 11l)</u></a>	59
8.3	<a href="#"><u>Vector Control Worker Protection Kit (10 Persons)</u></a>	60
<b>Chapter 9. Domestic WASH Items (NFI)</b>		
9.1	<a href="#"><u>Semi Collapsible Plastic Jerry Can (10 litres)</u></a>	61
9.2	<a href="#"><u>Stacking Plastic Bucket (14 litres with Lid, Tap and Handle)</u></a>	62
<b>Chapter 10. Tools</b>		
10.1	<a href="#"><u>Global Position System GPS Unit (Garmin GPSMAP 78s)</u></a>	63
10.2	<a href="#"><u>Laser Distometer (Leica Disto D2)</u></a>	64
10.3	<a href="#"><u>Borehole/Well Dip Meter (100m or 200m)</u></a>	65



# **SECTION ONE**

## **WATER PUMPING**



Item Application Sample



General Information and Description

A reliable and robust 2" centrifugal pump directly coupled to a diesel engine, supplied with suction and discharge hoses. Kit includes hoses, all fittings for initial set-up and operation of the pump and service spares for the first year of operation. The kit may be used in many emergency response applications including pumping water from a surface water source, water tanking operations, water treatment operations, or piped water supply.

Technical Specifications

**Pump:** Single stage centrifugal self-priming pump with 2" (50mm) BSP male suction and 2" (50mm) BSP male connections. Cast iron construction with 2 stage mechanical carbon/ceramic seal, stainless steel shaft sleeve, renewable steel wear plate, semi open clog resistant impeller, integral non-return valve, detachable discharge bend, casing clean out cover, and prime and drain points.

**Engine:** Single cylinder, 4 stroke air-cooled, diesel engine developing at least 4.5 KW at 3600 rpm with recoil start and starting handle, renewable element air, oil and fuel filters, 3 litre (3 hour) fuel tank, automatic low oil shut down, throttle control, oil drain tap and exhaust silencer. Pump and engine are close coupled together and mounted on a common fabricated steel chassis drilled with 4 holes for holding down bolts.

**Performance:** Pump should be capable of satisfying performance criteria as per pump curve below (curve going from 40m<sup>3</sup>/hr at 10 m head, through 28m<sup>3</sup>/hr at 20m head to 8m<sup>3</sup>/hr at 30m head). Pump should be capable of delivering up to 7m suction head.

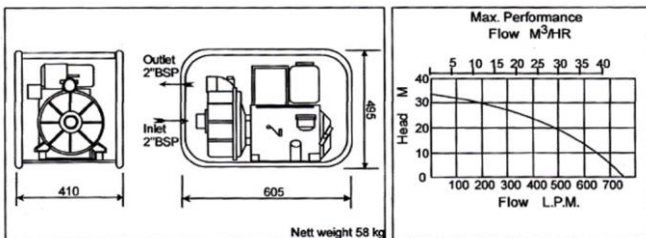

Weight, Volume and Packaging

Gross weight: 185 kg      Volume: 0.87 m<sup>3</sup>

Dimensions: 100 x 100 x 87 cm

**Packaging:** All the items shall be packed in a timber crate suitable for sea / air freight. The pump shall be bolted to the base of the crate using steel spreaders and 'nylock' type nuts. The case shall be finished with a minimum of two steel bands.

Components Included in Kit

Pumpset:

1 x 2" centrifugal pump directly coupled to a diesel engine.

Suction side fittings:

- 1 x 2" hose, length 30 m, reinforced plastic flexible medium duty, (green low toxic), max working pressure 3.5 bar burst 10 bar.
- 1 x 50 mm foot valve (SOCLA type - fitted to the above hose).
- 1 x 2" hose band (fitted to above).
- 1 x 2" BSP (female) hose coupling MI (fitted to above).
- 1 x 2" hose clamp (fitted to above).

Discharge side fittings:

- 1 x 2" hose, 5 m long, transparent PVC medium duty (5 bar), max working pressure 5 bar burst 10 bar.
- 2 x 2" BSP (female) hose coupling MI (fitted to both hose ends).
- 1 x 2" non-return valve, 2" BSP (female), brass (fitted to above).
- 1 x 2" gate valve BSP (female), brass (fitted to above).
- 2 x 2" nipple - hex BSP (male), brass (fitted to above).
- 2 x 2" reducer - nipple, 3" BSP (male) to 2" BSP (male), GI.
- 2 x 2" reducer - bush, 3" BSP (male) to 2" BSP (female), GI.
- 1 x 2" hose coupling, BSP (female), MI (fitted to above).
- 1 x 2" hose clamp (fitted to above).
- 3 x 10m roll of PTFE tape (12 mm wide).

Spares and consumables for 1 year of operation:

- 1 x centrifugal pump mechanical seal.
- 1 x centrifugal pump gasket set.
- 8 x diesel engine air filter element.
- 8 x diesel engine oil filter element.
- 8 x 'o' ring for diesel engine oil filter.
- 8 x diesel engine fuel filter element.
- 2 x diesel engine gasket set.
- 8 x diesel engine sump plug washer.
- 1 x 5 litres 15w/40 engine oil.
- 1 x basic tool kit: strap wrench, hexagonal key set, 13mm combination spanner, adjustable wrench 300mm, pliers.

Additional Notes / Resources

- The 5 litres of oil supplied in this kit should be used for running in the engine and discarded after 100 running hours and replaced with SAE 15W/40 lubricating oil.
- 2" suction and delivery pipework is supplied. 3" reducers are provided to allow connection to other water supply equipment.

[Surface Water Pumping Manual – Oxfam \(PDF 0.6 MB\)](#)

Note: last updated, April 2020

Item Application Sample



General Information and Description

A reliable and robust 4" centrifugal pump directly coupled to a diesel engine, supplied with suction and discharge hoses. Kit includes hoses, all fittings for initial set-up and operation of the pump and service spares for the first year of operation. The kit may be used in many emergency response applications including pumping water from a surface water source, water tanking operations, water treatment operations, or piped water supply.

Technical Specifications

**Pump:** Single stage centrifugal self-priming pump with 4" (100mm) BSP male suction and 4" (100mm) BSP male delivery connections. Cast iron construction with 2 stage mechanical carbon/ceramic seal, stainless steel shaft sleeve, renewable steel wear plate, semi open clog resistant impeller, integral non-return valve, detachable discharge bend, casing clean out cover, and prime and drain points.

**Engine:** Twin cylinder, 4 stroke air-cooled, diesel engine developing at least 4.5 KW at 3600 rpm with recoil start and starting handle, renewable element air, oil and fuel filters, 14.5 litre (4.5 hour) fuel tank, automatic low oil shut down, throttle control, fuel/water separator (agglomerator), oil drain tap and exhaust silencer. Pump and engine are close coupled together and mounted on a common fabricated steel chassis drilled with 4 holes for holding down bolts (4 x M10).

**Performance:** Pump should be capable of satisfying performance criteria as per pump curve below (curve going from 140m<sup>3</sup>/hr at 10 m head, through 125m<sup>3</sup>/hr at 20m head to 85m<sup>3</sup>/hr at 30m head). Pump should be capable of delivering up to 7m suction head.

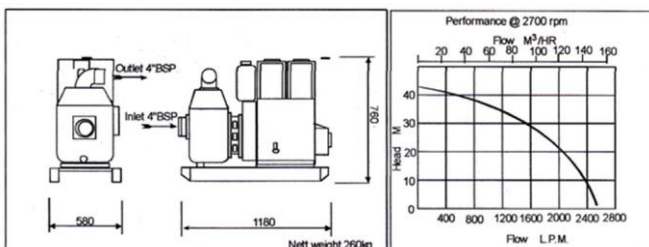

Weight, Volume and Packaging

Gross weight: 526 kg

Volume: 3.04 m<sup>3</sup>

Dimensions: 158 x 132 x 146 cm

**Packaging:** All the items shall be packed in a timber crate suitable for sea / air freight. The pump shall be bolted to the base of the crate using steel spreaders and 'nylock' type nuts. The case shall be finished with a minimum of two steel bands.

Components Included in Kit

**Pumpset:**

1 x 4" centrifugal pump directly coupled to a diesel engine.

**Suction side fittings:**

- 1 x 4" hose, length 10 m, reinforced plastic flexible medium duty. (green low toxic), max working pressure 3 bar burst 9 bar.
- 1 x 100 mm foot valve (SOCLA type - fitted to the above hose).
- 1 x 4" hose band (fitted to above).
- 1 x 4" BSP (female) hose coupling MI (fitted to above).
- 1 x 4" hose clamp (fitted to above).
- 1 x 4" reducing bush, 4" BSP (male) x 3" BSP (female), GI.
- 1 x 3" nipple, hex, BSP (male), GI.

**Discharge side fittings:**

- 1 x 3" hose, 5 m long, transparent PVC medium duty (5 bar), max working pressure 10 bar burst 30 bar.
- 2 x 3" BSP (female) hose coupling MI (fitted to both hose ends).
- 1 x 3" non-return valve, 2" BSP (female), brass (fitted to above).
- 1 x 3" gate valve BSP (female), brass (fitted to above).
- 5 x 3" nipple – hex BSP (male), brass (fitted to above).
- 1 x 4" reducer bush, 4" BSP (male) to 3" BSP (female), GI.
- 2 x 3" elbow 90°, 3" BSP (female), GI (fitted to above).
- 2 x 3" hose coupling, BSP (female), MI (fitted to above).
- 2 x 3" hose clamp (fitted to above).
- 3 x 10m roll of PTFE tape (12 mm wide).

**Spares and consumables for 1 year of operation:**

- 1 x centrifugal pump mechanical shaft seal.
- 1 x centrifugal pump gasket set (inlet, outlet and body).
- 1 x centrifugal pump 'o' ring.
- 2 x centrifugal pump plug and plug washer.
- 8 x diesel engine air filter element.
- 8 x diesel engine oil filter element.
- 8 x diesel engine fuel filter element.
- 1 x 5 litres 15w/40 engine oil.
- 1 x basic tool kit: strap wrench, hexagonal key set, 13mm combination spanner, adjustable wrench 300mm, pliers.

Additional Notes / Resources

- The 5 litres of oil supplied in this kit should be used for running in the engine and discarded after 100 running hours and replaced with SAE 15W/40 lubricating oil.
- The kit is supplied with a 4" suction hose however 3" reducers are provided to allow a 3" suction hose to be connected if required.

[Surface Water Pumping Manual – Oxfam \(PDF 4.2 MB\)](#)

Note: last updated, April 2020

**Item Application Sample**



**General Information and Description**

A robust electrical, dewatering/desludging pump capable of handling heavily contaminated water with solids up to 30mm. Maximum head 20m. Kit includes 400V three phase electrical generator, hoses, all fittings for initial set-up and operation and service spares for 1,000 hours of operation. The kit may be used for well dewatering, well cleaning, emptying pit latrines, draining ponds, or transfer of grey or black waters.

**Technical Specifications**

**Pump:** A 2" (50 mm) immersible/submersible pump with cast iron casing, and stainless steel screw type impeller capable of handling solids up to 30mm. The pump is equipped with removable steel strainer and cook anti-dive plate. The outer faces of the pump are coated with a high thickness, corrosion resistant epoxy paint. The pump is directly driven by 1.5kW, 400V, 3 phase, 50Hz, IP68 electric motor. Complete with 2" (50mm) male hose tail outlet and 25 metres of cable with 16A plug. The cable is looped and cleated around the pump handle to prevent strain on the internal connections. The pump is capable of dry running and is rated for continuous operation with overload protection.

**Generator:** 6000 watt, 400 volt, 3 phase, 50Hz brushless generator fitted with: hours counter, 1x 16 amp output socket protected by a power circuit breaker (ground fault detector), and earth leakage trip (to prevent fatal electric shocks should the power lead or pump develop a fault or be damaged). The generator is directly flange coupled to petrol engine, governed to run at 3000 rpm complete with recoil starter, 3 hour fuel tank, low oil protection, exhaust system, and air and oil filters. The generator unit is mounted on a two wheel site trolley equipped with anti-vibration mounts inside a robust tubular roll frame.

**Performance:** The dewatering pump should be capable of satisfying performance criteria as per pump curve below (17m<sup>3</sup>/hr at 15m head). The package is designed for dewatering wells up to 15m. For deeper wells it may be necessary to mount two pumps in series to achieve 7.5 m<sup>3</sup>/hr at 35m head (refer to *Oxfam Surface Water Pumping Manual*).

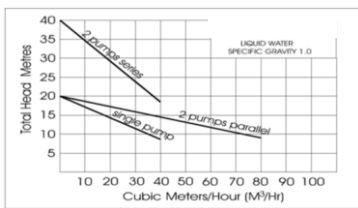
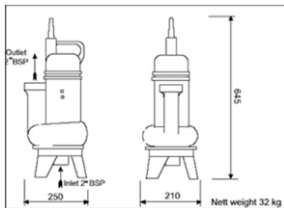

**Components Included in Kit**

- Pump:**
- 1 x Dewatering pump capable of 17m<sup>3</sup>/hr at 15m head.
  - 1 x Layflat hose 25m, 5 bar rating, 2", canvas.
  - 1 x Hose coupling, 2" BSP (male), brass (attached to above).
  - 4 x Hose clip 2" (attached to above).
  - 1 x Nylon rope 40m, 16mm.
  - 1 x Sliding protective collar 1m length 3" diameter - to fit over the layflat where it exits the well.

- Generator:**
- 1 x 16A electrical extension cable 20m with socket connectors.

- Spares and consumables for 1000 hours of operation:**
- 2 x Spark plugs.
  - 2 x Air filter elements.
  - 2 x Oil filter elements.
  - 1 x 5 litres 15w/40 engine oil.
  - 1 x 16A plug.
  - 2 x 2" hose clip.
  - 1 x basic toolkit, comprising: spark plug spanner, screwdriver and oil drain spanner.

Instruction, operating and maintenance manual shall be included in addition to spare parts lists for the pump and the engine.

**Weight, Volume and Packaging**

- Gross weight:** 210 kg      **Volume:** 0.83 m<sup>3</sup>
- Dimensions:** 112 x 77 x 101 cm
- Packaging:** Items packed in a sturdy timber crate suitable for sea / air freight.

**Additional Notes / Resources**

- The 5 litres of oil supplied in this kit should be used for running in the engine and discarded after 100 running hours and replaced with SAE 15W/40 lubricating oil.
- The kit can be supplied with either a diesel engine (5.5kW/3000rpm) or petrol engine (6kW/3000rpm).

[Hand Dug Well Equipment – Oxfam \(PDF 4.2 MB\)](#)  
[Surface Water Pumping Manual – Oxfam \(PDF 4.2 MB\)](#)

Note: last updated, April 2020



Item Application Sample



General Information and Description

Electrical submersible pump for medium sized borehole installations up to 60m deep. The kit includes all items for a complete installation including pump, 6kVA generator, 1½" rising main, direct on line starter, electrical controls and all fittings for the wellhead assembly. Note that pump is fitted with a 4" cooling sleeve and is only suitable for installation inside boreholes of greater than 4 ½" (120mm).

Technical Specifications

**Pump:** Multi-stage 3" submersible pump for pumping of non-aggressive water without solid particles from boreholes. Fabricated with corrosion resistant stainless steel body and shaft, impeller/diffuser assemblies, water lubricated bearings, top non-return valve, and bottom strainer and complete with electric cabling. Rated flow 5.8m<sup>3</sup>/hr at 60m total head. Fitted with single phase 220V electric motor with a power requirement of 2.2kW (approx. 4kW for starting). Complete with dry run, under/over voltage, and phase loss protection.

**Generator:** 6kVA, 230 volt, single phase, 50Hz brushless generator fitted with: hours counter, 1x 16 amp output socket protected by a power circuit breaker (ground fault detector), and earth leakage trip. Powered by water-cooled diesel engine complete with: 12 volt removable key type electric start/stop, battery charging and 12 volt battery pack (suitable for airfreight), mounted 22.5 hour fuel tank, engine protection for low oil level, low tone exhaust and acoustic shield (76 dba at 7 metres). Fuel consumption 1.3l/hr at 75% load.

**Performance:** Pump should be capable of satisfying performance criteria as per pump curve below (curve going from 7.3m<sup>3</sup>/hr at 30 m head, through 5.8m<sup>3</sup>/hr at 60m head to 3.3m<sup>3</sup>/hr at 90m head).

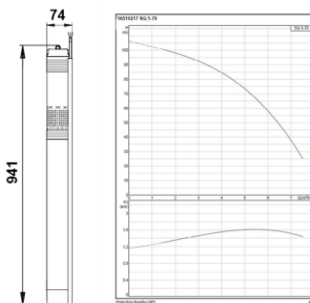

Weight, Volume and Packaging

Gross weight pump: 246 kg

Gross weight generator: 274 kg

Dimensions: 120 x 52 x 100 cm

Dimensions: 120 x 63 x 106 cm

Packaging: Durable timber crate suitable for sea / air freight.

Components Included in Kit

**Pump:**

- 1 x Submersible pump + MS3 single phase motor.
- 1 x 80m length, 4mm<sup>2</sup> 3 core pump drop cable with 3-pin plug.
- 1 x Flow sleeve kit 4" (pre-fitted by the supplier).
- 1 x Electrical protection/switching panel with protection relay, pull-in type contactor with stop/start buttons, weatherproof casing, pre-wired trailing leads and M/F 16A plugs, and pre-set protection/delay settings.

**Generator:**

- 1 x 6kVA generator set with diesel engine.
- 1 x Earthing spike, copper, with cable.
- 1 x 1,000 hours spares kit comprising: 4 x oil filters, 4 x fuel filters, 4 x air filters, 1 x engine oil 5 litres 10W30, 1 x fuel can 20 litres.

**Rising main, wellhead assembly and accessories:**

- 1 x Boreline flexible rising main, 1½" x 60m.
- 1 x Stainless steel cable 65m x 4mm with shackles and eyes.
- 55 x Boreline fixing straps, blue and 5 x Boreline fixing straps, red.
- 2 x Boreline rising main stubs, 2" BSP (male) x 1½", stainless steel with double-ring couplings.
- 1 x Pack of cable ties 8mm x 150mm (100pcs).
- 20 x Dipper tubes 19mm threaded male/female 3m lengths.
- 1 x Wellhead assembly, 2", mild steel comprising of: Head plate mild steel, 2" 90° sweep bend and outer casing 200mm Ø.
- 1 x Non-return valve assembly comprising of: 2" hex nipple BSP (male), 2" BSP (female) brass non-return valve, 300mm barrel nipple 2" BSP (male), and 50mm flange 2" BSP 4 holes PN16.
- 1 x Control valve assembly comprising of: 50mm flange 2" BSP 4 holes PN16, steel nipple 1m length 2" BSP (female) steel, Woltmann type flow meter 50mm PN16 supplied with gaskets, bolts, nuts and washers, 3 x hex nipples 2" BSP (male) GI, 2 x elbows 90°, 2" BSP (female), GI, 1 x tee, reduced branch 2x½" BSP (female) GI with ½" brass ball valve, heavy duty bottom entry glycol filled pressure gauge ½" BSP (male) 16-20 bar max, 2" BSP (female) gate valve brass PN16, and 1 x tee, reduced branch, 2" x ½" BSP (female) GI with ½" brass hose connector.
- 1 x Basic installation kit: hexagonal key set, 10 x rolls PTFE tape, 6 x rolls Loctite 55 thread, 6 x rolls insulating tape.

Additional Notes / Resources

- The kit includes an optional generator that matches the pump. Even if there is adequate electrical supply it is recommended the generator is ordered in case of power cuts.

Note: last updated, April 2020

Item Application Sample



General Information and Description

Electrical submersible pump for borehole installations from 60m to 100m deep. The kit includes all items for a complete installation including pump, 16kVA generator, 2" rising main, soft starter, electrical controls and all fittings for the wellhead assembly.

Technical Specifications

**Pump:** Multi-stage 4" submersible pump for pumping of non-aggressive water without solid particles from boreholes. Fabricated with corrosion resistant stainless steel body and shaft, impeller/diffuser assemblies, water lubricated bearings, top non-return valve, and bottom strainer and complete with electric cabling. Rated flow 8m<sup>3</sup>/hr at 107m head. Fitted with three phase 400V electric motor with a power requirement of 3.7kW (allow at least 12kVA for starting). Complete with dry run, under/over voltage, and phase loss protection.

**Generator:** 16kVA 50Hz brushless generator with multi-voltage, multi-phase circuit breaker protected socket panel comprising the following outputs: (1x) 16A 115V, (1x) 32A 115V, (1x) 16A 230V, (1x) 32A 230V, (1x) 16A 400V, and (1x) 32A 400V protected by power circuit breaker (ground fault detector) and earth leakage trip. Powered by water-cooled diesel engine complete with: tropical radiator, 12 volt removable key type electric start/stop, battery charging and 12 volt battery pack (suitable for airfreight), mounted 50 litre (14 hours at 75% load) fuel tank, engine protection for low oil level, low tone exhaust and acoustic shield (60.7 dba at 7 metres). Fitted with stop/start control panel rev counter, battery voltage and hours run counter. Skid-mounted with lockable weather proof enclosure.

**Performance:** Pump should be capable of satisfying performance criteria as per pump curve below (curve going from 9.7m<sup>3</sup>/hr at 80 m head, through 8.4m<sup>3</sup>/hr at 100m head to 6.7m<sup>3</sup>/hr at 120m head).

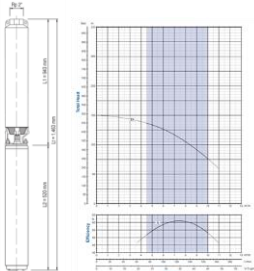

Weight, Volume and Packaging

Gross weight pump: 284 kg      Gross weight generator: 721 kg  
Dimensions: 131 x 67 x 120 cm      Dimensions: 206 x 87 x 148 cm  
Packaging: Durable timber crate suitable for sea / air freight.

Components Included in Kit

- Pump:**  
1 x 4" multi-stage submersible pump.  
1 x 3.7 kW motor.  
1 x 110m length, 4mm<sup>2</sup> 3 core pump drop cable with 4-pin plug.
- Generator:**  
1 x 16kVA 50Hz generator powered by water cooled diesel engine.  
1 x Earthing spike 1.2m, copper, with cable.  
1 x 1,000 hours spares kit comprising: 4 x oil filters, 4 x fuel filters, 4 x air filters, 2 x fan belts, 1 x engine oil 20 litres 10W30, 1 x fuel can 20 litres.
- Rising main, wellhead assembly and accessories:**  
1 x Flexible rising main, 2" x 100m.  
2 x Rising main couplings, 2" BSP (male), stainless steel with double-ring clamps, bolts and spare bolts.  
1 x Hi-torque tie-wraps for flexible rising main – (100pcs)  
1 x Cable saddles – (100pcs).  
1 x Bend, 90°, 2" BSP(M-F), GI.  
34 x Dipper tubes 25mm threaded male/female 3m lengths.  
1 x Wellhead assembly, 2", mild steel with hole for dip tube and cable.  
1 x Non-return valve assembly comprising of: 2" hex nipple BSP (male), 2" BSP (female) brass non-return valve, 300mm barrel nipple 2" BSP (male), and 50mm flange 2" BSP 4 holes PN16.  
1 x Control valve assembly comprising of: 50mm flange 2" BSP 4 holes PN16, steel nipple 1m length 2" BSP (female) steel, Woltmann type flow meter 50mm PN16 supplied with gaskets, bolts, nuts and washers, 3 x hex nipples 2" BSP (male) GI, 2 x elbows 90°, 2" BSP (female), GI, 1 x tee, reduced branch 2x1/2" BSP (female) GI with 1/2" brass ball valve, heavy duty bottom entry glycol filled pressure gauge 1/2" BSP (male) 16-20 bar max, 2" BSP (female) gate valve brass PN16, and 1 x tee, reduced branch, 2" x 1/2" BSP (female) GI with 1/2" brass hose connector.  
1 x Basic installation kit: 2 x water pump pliers 70mm opening, hexagonal key set, torque wrench plus adapter set and 4mm and 5mm sockets, 10 x rolls PTFE tape, 6 x rolls Loctite 55 thread, 6 x rolls insulating tape, 1 x knife, 1 x file, 1 x spanner combination 13mm.

Additional Notes / Resources

- The kit includes an optional generator that matches the pump. Even if there is adequate electrical supply it is recommended the generator is ordered in case of power cuts.

Note: last updated, April 2020

Item Application Sample



General Information and Description

A low yield solar powered electrical submersible pump for borehole installations up to 40m deep. The kit includes all items for a complete installation including pump, rising main, starter, electrical controls and all fittings for the wellhead assembly. Power is provided by a complete solar panel kit that includes panels, mounting frame, cables, inverter, control panel and a switch for either solar or 230V AC power.

Technical Specifications

**Pump:** Multi-stage 3" submersible pump for pumping of non-aggressive water without solid particles from boreholes. Fabricated with corrosion resistant stainless steel body and shaft, impeller/diffuser assemblies, water lubricated bearings, top non-return valve, and bottom strainer and complete with electric cabling. Rated flow 2.0m<sup>3</sup>/hr at 40m total head. Fitted with single phase 230V electric motor with a power requirement of 0.6kW. Complete with dry run, under/over voltage, and phase loss protection.

**Solar:** Kit of four mono crystalline 37.4Vmp, 205W peak solar panels that can be connected to provide a maximum of 820 W (peak power). Supplied with an adjustable mounting frame for permanent installation of the units at the correct solar inclination.

**Performance:** Pump should be capable of satisfying performance criteria as per pump curve below (curve going from 2.0m<sup>3</sup>/hr at 40 m head, through 1.5m<sup>3</sup>/hr at 46m head to 1.0m<sup>3</sup>/hr at 53m head).

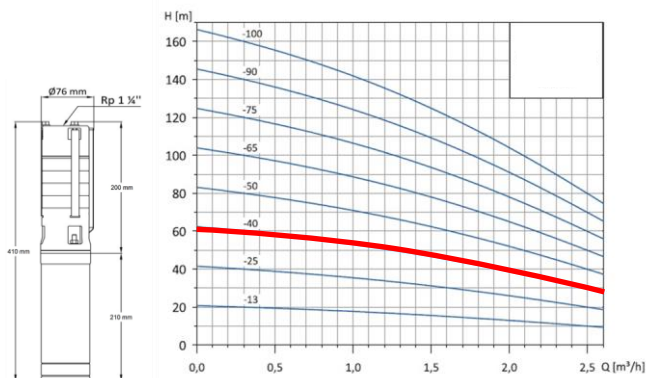

Weight, Volume and Packaging

Gross weight pump: 104 kg      Gross weight solar kit: 197 kg  
Dimensions: 102 x 45 x 102 cm      Dimensions: 183 x 53 x 108 cm  
Packaging: Durable timber crate suitable for sea / air freight.

Components Included in Kit

- Pump:**
- 1 x Submersible 3" pump with 0.6kW 230V motor.
  - 1 x 60m 4mm<sup>2</sup> 3 core pump drop cable with 3-pin plug (pre-fitted).
  - 1 x Electrical switching panel with stop/ start buttons, weatherproof casing, pre-set protection/delays and solar/gen switch.
  - 1 x Pump spares kit consisting of : 3 x impellers, 2 x diffusers (bottom and top diffuser), 3 x spacer straps, 1 x cable jointing kit

- Solar panel kit:**
- 4 x Mono crystalline solar panels, 37.4Vmp, 205W peak.
  - 1 x Solar controller 1000W with AC/DC inverter 1000W.
  - 1 x Earthing spike, 1.2m copper, with cable.
  - 4 x 10m, 4mm<sup>2</sup>, PV cable type MC4 (one with single female plug, one with single male plug, two with male-female plugs).
  - 1 x Fully adjustable mounting frame fabricated in galvanised steel.

- Rising main, wellhead assembly and accessories:**
- 1 x Boreline flexible rising main, 1 1/2" x 60m.
  - 1 x Stainless steel cable 65m x 3mm with shackles and eyes.
  - 55 x Boreline fixing straps, blue and 5 x Boreline fixing straps, red.
  - 2 x Boreline rising main stubs, 2" BSP (male) x 1 1/2", stainless steel with double-ring couplings.
  - 1 x Pack of cable ties 8mm x 150mm (100pcs).
  - 20 x Dipper tubes 19mm threaded male/female 3m lengths.
  - 1 x Wellhead assembly, 2", mild steel comprising of: Head plate mild steel, 2" 90° sweep bend and outer casing 200mm Ø.
  - 1 x Non-return valve assembly comprising of: 2" hex nipple BSP (male), 2" BSP (female) brass non-return valve, 300mm barrel nipple 2" BSP (male), and 50mm flange 2" BSP 4 holes PN16.
  - 1 x Control valve assembly comprising of: 50mm flange 2" BSP 4 holes PN16, steel nipple 1m length 2" BSP (female) steel, Woltmann type flow meter 50mm PN16 supplied with gaskets, bolts, nuts and washers, 3 x hex nipples 2" BSP (male) GI, 2 x elbows 90°, 2" BSP (female), GI, 1 x tee, reduced branch 2x1/2" BSP (female) GI with 1/2" brass ball valve, heavy duty bottom entry glycol filled pressure gauge 1/2" BSP (male) 16-20 bar max, 2" BSP (female) gate valve brass PN16, and 1 x tee, reduced branch, 2" x 1/2" BSP (female) GI with 1/2" brass hose connector.
  - 1 x Basic installation kit: hexagonal key set, 10 x rolls PTFE tape, 6 x rolls Loctite 55 thread, 6 x rolls insulating tape.

Additional Notes / Resources

- The kit is selected to be capable of delivering approximately 10 m<sup>3</sup>/day at 10-30 m total head, based on general solar irradiation figures between 20° North and South of the Equator. Additional panels may be required in locations with less solar irradiation.

Note: last updated, April 2020

Item Application Sample



General Information and Description

A 4" solar powered electrical submersible pump for borehole installations up to 70m deep. The kit includes all items for a complete installation including pump, rising main, starter, electrical controls and all fittings for the wellhead assembly. Power is provided by a complete solar panel kit that includes panels, mounting frame, cables, and solar regulator and control unit.

Technical Specifications

**Pump:** Multi-stage 4" submersible pump for pumping of non-aggressive water without solid particles from boreholes. Fabricated with corrosion resistant stainless steel body and shaft, impeller/diffuser assemblies, water lubricated bearings, top non-return valve, and bottom strainer and complete with electric cabling. Rated flow 4.0m<sup>3</sup>/hr at 70m total head. Fitted with eco-drive variable speed and voltage DC electric motor with a maximum power requirement of 1.8kW. Complete with dry run, under/over voltage, phase loss protection and integrated MPPT (Maximum Power Point Tracking).

**Solar:** Kit of four mono crystalline 37.4Vmp, 205W peak solar panels that can be connected to provide a maximum of 820 W (peak power). Supplied with an adjustable mounting frame for permanent installation of the units at the correct solar inclination. Note that either one, two or three 820 W (peak) solar panel kits may be required based on the desired duty point (head and flow), the power requirement, and the available solar irradiance at the installation location.

**Performance:** Pump should be capable of satisfying performance criteria as per pump curves below (from 4.0m<sup>3</sup>/hr at 70 m head, through 5.4m<sup>3</sup>/hr at 50m head to 6.8m<sup>3</sup>/hr at 30m head).

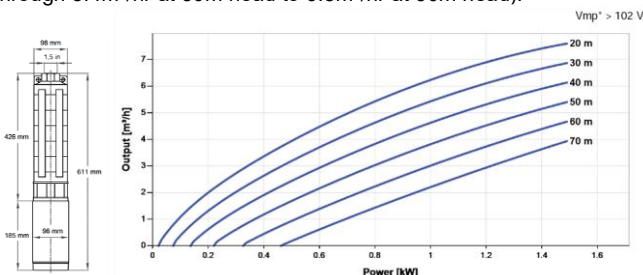

Weight, Volume and Packaging

Gross weight pump: 180 kg      Gross weight solar kit: 197 kg  
Dimensions: 102 x 45 x 102 cm      Dimensions: 183 x 53 x 108 cm  
Packaging: Durable timber crate suitable for sea / air freight.

Components Included in Kit

- Pump:**
- 1 x Multi-stage submersible pump with motor.
  - 1 x 70m 4mm<sup>2</sup> 3 core pump drop cable with 3-pin plug (pre-fitted).
  - 1 x Electrical switching panel 440V DC / 20A with stop/ start buttons, weatherproof casing, and pre-set protection/delays.
  - 1 x Pump controller, 1.8kVA, programmable for solar (PV)/ battery direct operation.
  - 1 x Surge protection unit.
  - 1 x Well probe sensor - for low water control with 70m cables.
  - 1 x Float switch - for tank full control with cables.
- Solar panel kit:**
- 12 x Mono crystalline solar panels, 37.4Vmp, 205W peak.
  - 12 x 10m, 4mm<sup>2</sup>, PV cable type MC4 (three with single female plug, three with single male plug, six with male-female plugs).
  - 1 x Fully adjustable mounting frame fabricated in galvanised steel.
- Rising main, wellhead assembly and accessories:**
- 1 x Boreline flexible rising main, 1½" x 70m.
  - 1 x Polyester rope 70m x 6mm (pump safety rope).
  - 65 x Boreline fixing straps, blue and 5 x Boreline fixing straps, red.
  - 2 x Boreline rising main stubs, 2" BSP (male) x 1½", stainless steel with double-ring couplings.
  - 1 x Pack of cable ties 8mm x 150mm (100pcs).
  - 20 x Dipper tubes 19mm threaded male/female 3m lengths.
  - 1 x Wellhead assembly, 2", mild steel comprising of: Head plate mild steel, 2" 90° sweep bend and outer casing 200mm Ø.
  - 1 x Non-return valve assembly comprising of: 2" hex nipple BSP (male), 2" BSP (female) brass non-return valve, 300mm barrel nipple 2" BSP (male), and 50mm flange 2" BSP 4 holes PN16.
  - 1 x Control valve assembly comprising of: 50mm flange 2" BSP 4 holes PN16, steel nipple 1m length 2" BSP (female) steel, Woltmann type flow meter 50mm PN16 supplied with gaskets, bolts, nuts and washers, 3 x hex nipples 2" BSP (male) GI, 2 x elbows 90°, 2" BSP (female), GI, 1 x tee, reduced branch 2x½" BSP (female) GI with ½" brass ball valve, heavy duty bottom entry glycol filled pressure gauge ½" BSP (male) 16-20 bar max, 2" BSP (female) gate valve brass PN16, and 1 x tee, reduced branch, 2" x ½" BSP (female) GI with ½" brass hose connector.
  - 1 x Basic installation kit: 1 x pipe wrench 300mm, 1 x adjustable wrench 300mm, 1 x wire crimping tool, 1 x hexagonal key set, 10 x rolls PTFE tape, 6 x rolls Loctite 55 thread, 6 x rolls insulating tape.

Additional Notes / Resources

- The kit is selected to be capable of delivering approximately 4 m<sup>3</sup>/hr at 70 m total head, based on general solar irradiation figures between 20° North and South of the Equator. Additional panels may be required in locations with less solar irradiation.

Note: last updated, April 2020

Item Application Sample



General Information and Description

Heavy duty, reliable, corrosion resistant, easy to install, operate and maintain lever action hand pump for installation in wells and boreholes up to 45 m deep. Complete package, for 40 metres installation depth with UPVC riser pipes and pump rods. Meets VLOMM (Village Level of Operation Maintenance and Management) criteria. Installation is simple and does not require lifting equipment. Specification is open to the public domain and maintained by SKAT-RWSN.

Technical Specifications

All parts conforming to SKAT-RWSN Specifications Rev. 5:2007:

**Pump Body:** Galvanized steel handpump with 300 mm spout, adjustable handle, compression cone assembly and stand.

**Pump Cylinder:** uPVC cylinder 50mm with brass lining, brass plunger and plastic foot valve. Rated performance at 30m of 700 litres / hour.

**Rising Main:** UPVC pipe, 3m length, 63mm ND, 4.7mm wall diameter, with bell and spigot.

**Pump Rods:** Stainless steel, 3m length, 10mm diameter, with threaded connectors.

Note that there are two pump stand variants 'A' and 'B' for use either with boreholes (three legs for embedding in concrete) or with hand dug wells (base with bottom flange plate, rubber gasket and anchor assembly for bolting onto cover slab).

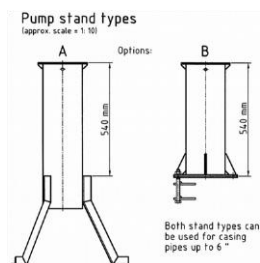

Weight, Volume and Packaging

Five (5) pump sets with accessories in three packages:

	Gross weight:	Volume:	Dimensions:
Package 1	300 kg	1.25 m <sup>3</sup>	118 x 96 x 110 cm
Package 2	270 kg	0.59 m <sup>3</sup>	138 x 79 x 54 cm
Package 3	150 kg	0.20 m <sup>3</sup>	325 x 25 x 24 cm

All the items packed in a timber crate suitable for sea / air freight.

Components Included in Kit

Handpump Kit:

- 1 x Pump head assembly, galvanized steel, 300mm spout.
- 1 x Pump head cover assembly, galvanized steel.
- 1 x Pump handle assembly, adjustable length, includes fulcrum pin, rod hanger assembly, and hanger pin assembly.
- 1 x Bearing bush assembly (outer and inner).
- 1 x Steel cone plate assembly, galvanized steel.
- 1 x Compression cone.
- 1 x Pump stand (specify either type 'A' with three legs or type 'B' with base flange plate, rubber gasket and anchor assembly)
- 1 x Pump cylinder assembly, 50mm uPVC cylinder with brass plunger, plastic foot valve, and fishing tool connector.
- 14 x Pump rods, stainless steel, 3m long, 10.0mm diameter, with threaded connectors and centralizers.
- 14 x Riser pipes, UPVC, 3m length, 63mm ND, 4.7mm wall diameter, with bell and spigot.
- 1 x Selection of riser pipe stabilisers for various sizes of casings (14 of each type 4", 4.5", 5" and 6").

Tools, Spares and Accessories Kit:

- 1 x Polypropylene support rope 6mm diameter, 100m length.
- 1 x UPVC cement jointing solvent 200ml.
- 1 x UPVC cement cleaning solvent 200ml.
- 1 x Selection of spanners: new DIN standard 2 x 16mm, 2 x 18mm, 1 x 24mm, old DIN standard 2 x 17mm, 2 x 19mm.
- 1 x Resting tool, galvanized steel.
- 1 x Connecting tool, galvanized steel.
- 1 x Spanner assembly.
- 1 x Fishing tool for foot-valve.
- 1 x One year spares kit including spare centralizers, bush bearings, valve bobbins and seals.

Installation, operating and maintenance manual shall be included in addition to a spare parts lists and maintenance card.

Additional Notes / Resources

- In Pakistan and Afghanistan SKAT-RWSN have produced three Afridev variant quality specifications under the names of Indus, Kabul and Pamir pumps: the Indus pump follows the exact Afridev specification; the Kabul pump is of lower quality than the Afridev specification and significantly cheaper; the Pamir pump is an Afridev variant with a bottom support allowing it to pump to 80m.

- [Afridev Handpump Specification - RWSN \(PDF 68.2 MB\)](#)
- [Afridev Installation and Maintenance Manual - RWSN \(PDF 3.2 MB\)](#)
- [Afridev Handpump Maintenance Card - RWSN \(PDF 0.2 MB\)](#)
- [Indus, Kabul and Pamir Specifications - RWSN \(PDF 59.6 MB\)](#)

Note: last updated, April 2020

Item Application Sample



General Information and Description

Heavy duty, reliable, easy to install, operate and maintain lever action hand pump for installation in wells and boreholes up to 50 m deep. Meets VLOMM (Village Level of Operation Maintenance and Management) criteria. Installation is simple and does not require heavy lifting equipment. Specification is open to the public domain and maintained by SKAT-RWSN. Complete package, for 40 metres installation depth with GI riser pipes and mild steel pump rods.

Technical Specifications

All parts conforming to SKAT-RWSN Specifications Rev. 2:2007:

**Pump Body:** Galvanized steel handpump with heavy counterweight handle, chain assembly, compression cone, water tank and stand.

**Pump Cylinder:** Cast iron / brass cylinder, brass plunger and foot valve. Available as either 50mm high lift or 63mm medium lift version. Rated performance of 63mm cylinder at 30m is 800 litres / hour.

**Rising Main:** GI pipe, 3m length, either 50mm / 2" or 63mm / 2½".

**Pump Rods:** 3m length, galvanized mild steel, 12mm diameter, with M12 threaded connectors.

Note that there are three pump stand variants. 'A' and 'B' for use with boreholes (with three legs for embedding in concrete); 'A' for 4", 4.5" and 5" boreholes; 'B' for 6" boreholes; and 'C' for hand dug wells up to 6" (flange plate, gasket and anchor assembly).

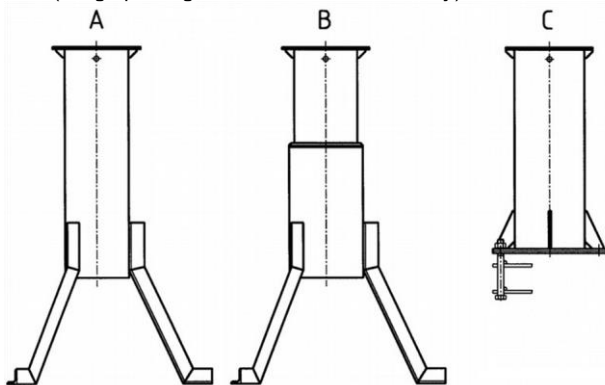

Weight, Volume and Packaging

Gross weight: 244 kg

Volume: 0.53 m<sup>3</sup>

Packaging: Pump body and parts packed in a sturdy timber crate suitable for sea / air freight. Riser pipes and pump rods to be steel strapped into bundles.

Components Included in Kit

**Handpump Kit: State either 50mm or 63 mm version**

- 1 x Pump head and cover assembly, galvanized steel.
- 1 x Pump handle, galvanized steel
- 1 x Pump chain assembly includes axle and bearings.
- 1 x Water tank assembly, galvanized steel.
- 1 x Compression cone.
- 1 x Pump stand (specify either type 'A', 'B', or 'C')
- 1 x Pump cylinder assembly, cast iron / brass cylinder with brass plunger, and brass foot valve.
- 14 x Pump rods, mild steel, 3m long, 12mm diameter, with threaded connectors and centralizers.
- 14 x Riser pipes, GI, 3m length.

**Tools, Spares and Accessories Kit:**

- 1 x Connecting tool assembly.
- 1 x Pipe clamp assembly.
- 1 x Bearing mounting assembly.
- 1 x Chain support
- 1 x Axle punch
- 1 x Pipe vice assembly
- 1 x Pump rod vice assembly
- 2 x Lifting spanners 2½".
- 2 x Pipe wrench 2½".
- 1 x Selection of spanners: new DIN: 2 x 10mm, 2 x 16mm, 2 x 18mm, 1 x 24mm, old DIN standard: 2 x 17mm, 2 x 19mm.
- 1 x Spares kit including 2 x pump bucket, 2 x bobbin, 4 x "O" ring seat for check valve, 2 x sealing rings, 4 x hex bolt M12 x 40, 2 x hex bolt M12 x 20, 8 x hex nut M12, 2 x washer 6H, 1 set x HT bolt M10 x 40 with nyloc nut, 200 gms x multipurpose grease.

Installation, operating and maintenance manual shall be included in addition to a spare parts lists and maintenance card.

Additional Notes / Resources

- This pump is not recommended for corrosive water with pH<6.5. If water is corrosive is better to install an Afridev.
- Make sure there is not confusion between the India Mark II and the India Mark III . The India Mark II handpump does not meet the criteria for VLOMM (Village Level of Operation Maintenance and Management).

[India Mark III Handpump Specification - RWSN \(PDF 17.2 MB\)](#)  
[India Mark III Installation and Maintenance Manual - \(PDF 3.3 MB\)](#)

Note: last updated, April 2020

## **SECTION TWO**

# **BULK WATER STORAGE**

Item Application Sample



General Information and Description

Robust collapsible and reusable water tanks made from food grade PVC material suitable for drinking water storage in 5,000 litre, 10,000 litre, 15,000 litre and 20,000 litre sizes. Bladder tanks are small, easily transportable and very quick to set up for short-term water provision typically in emergency settings. Kit is complete with groundsheet, basic fittings (control valves and fittings to allow connection to 32mm PE pipe), and repair kit. Kit does not include tapstands or pipe (these need to be ordered separately).

Technical Specifications

**Material:** UV resistant, mould and mildew resistant, food grade PVC coated polyester fabric (minimum 1100 g/m<sup>2</sup>) with thermal stability - 30°/+70°C. All materials used should be suitable for chlorinated drinking water.

**Reinforcement:** Water tank corners to be fitted with aluminium or plastic flanges for anchoring. Water tank inlet/outlet to be reinforced with a double layer of fabric. All seams to be either heat or high frequency welded. Outlets to be fitted with anti-chafe patch and flap.

**Inlet:** 1 x 100 mm (4") top threaded flanged inlet situated at the centre of the upper surface with PVC or polypropylene screw lid and captive chord.

**Outlets:** 2 x 50 mm (2") diameter male threaded bolted flange outlet stub, made of stainless steel, polypropylene or PVC, one port at each end of the water tank (for filling/inlet and discharging/outlet purposes). The ports are to remain horizontal once the tank is filled.

**Groundsheet:** Plastic sheet, minimum thickness 0.5 mm, must protrude over the 4 sides of the water tank by not less than 50 cm.

Weight, Volume and Packaging

	Gross weight:	Volume:	Dimensions:
5,000 litre	90 kg	0.48 m <sup>3</sup>	120 x 100 x 40 cm
10,000 litre	98 kg	0.48 m <sup>3</sup>	120 x 100 x 40 cm
15,000 litre	120 kg	0.60 m <sup>3</sup>	120 x 100 x 50 cm
20,000 litre	140 kg	0.72 m <sup>3</sup>	120 x 100 x 60 cm

**Packaging:** All the items shall be packed in a timber crate suitable for sea / air freight.

Components Included in Kit

**Bladder Kit:**

- 1 x PVC bladder tank (quote either 5m<sup>3</sup>, 10m<sup>3</sup>, 15m<sup>3</sup>, or 20m<sup>3</sup>).
- 1 x Plastic groundsheet 0.5mm.
- 1 x Holdall bag.

**Fittings Kit:**

- 2 x 2" gate valve (female) brass.
- 2 x 2" reducing bush, 2" BSP (male) to 1" BSP (female), GI.
- 2 x 32mm compression adapter 32mm - 1" BSP (male), PE.
- 2 x 32mm compression tee, PE.
- 2 x 2" nipple, hex, BSP (male), GI.
- 2 x Rolls PTFE tape 12mm x 30m.

**Installation Kit:**

- 2 x Pickaxes.
- 2 x Spades.
- 1 x Roll PVC barrier tape, 500m.
- 1 x Roll blue polypropylene rope, 50m.
- 1 x Spirit level 60cm.

**Repair Kit:**

- 1 x PVC repair patches material 1.0m x 0.5m.
- 1 x PVC glue "neoprene contact" 100 g tube.
- 1 x IATA approved container for PVC glue.
- 1 x Sand paper, wet and dry use, fine, n°120, A4 sheet.

Instruction, operating and maintenance manual shall be included in addition to spare parts lists.

Additional Notes / Resources

- The tank should be elevated to approximately 1.5m above the level of the tapstands to provide sufficient head for gravity feed. Options for elevating the tanks include earth mounds, oil drum platforms, wooden structures, or use of existing topography.
- Bladder tanks have a tendency to roll and care must be taken to ensure the installation location is perfectly flat.
- Not suitable for water treatment (coagulation/flocculation) or storing of turbid raw waters. Order Oxfam tanks or onion tanks instead. Bladder tanks are difficult to clean and should only be used to store clean and chlorinated water.
- If the bladders are to be used for transportation, make sure that the stronger trucking bladder is ordered. These bladders are not designed for transportation.

- [Water Storage Manual – Oxfam \(PDF 4.2 MB\)](#)
- [Water Bladder Installation and User Manual \(PDF 5.4 MB\)](#)
- [Water Bladder Cleaning Instructions \(PDF 3.2 MB\)](#)

Note: last updated, April 2020



Item Application Sample



General Information and Description

Small sealed flexible water tanks for water transportation and storage made from food grade PVC material suitable for drinking water. Bladder tanks are capable of holding 6,000m<sup>3</sup> of water and are suitable for mounting on the back of a 7 ton truck. Trucking bladders may be used for short-term water provision in emergency settings typically where water tankers are in short supply. Bladder is provided with heavy duty reinforced mounting points and heavy duty straps for securing the bladder to the truck. Kit includes groundsheet, basic fittings (control valves and fittings to allow connection to 32mm PE pipe), and repair kit. Kit does not include tapstands (these need to be ordered separately).

Technical Specifications

**Material:** UV resistant, mould and mildew resistant, food grade PVC coated polyester fabric (minimum 1100 g/m<sup>2</sup>) with thermal stability - 30°/+70°C. All materials used should be suitable for chlorinated drinking water. Maximum width of bladder should be 2.2m

**Reinforcement:** Water tank inlet/outlet to be reinforced with a double layer of fabric. All seams to be either heat or high frequency welded. Outlets to be fitted with anti-chafe patch and flap. Water tank corners to be fitted with four (4) heavy duty 50mm polyester webbing straps (two each end) for securing to truck body.

**Inlet:** 1 x 100 mm (4") top threaded flanged inlet situated at the centre of the upper surface with PVC or polypropylene screw lid and captive chord.

**Outlets:** 2 x 50 mm (2") diameter male threaded bolted flange outlet stubs, made of stainless steel or aluminium, both ports fitted at same end of the water tank (for filling/inlet and discharging/outlet purposes). The ports are to remain horizontal once the tank is filled.

**Pressure Relief:** Bladder tank to be fitted with two (2) pressure relief valves (maximum 2 psi) with rubber plugs.

**Groundsheet:** Plastic sheet, minimum thickness 0.5 mm to line truck bay. Must be 50 cm wider than the bladder tank on each side.

Weight, Volume and Packaging

	Gross weight:	Volume:	Dimensions:
6,000 litre	90 kg	0.48 m <sup>3</sup>	120 x 100 x 40 cm

**Packaging:** All the items shall be packed in a timber crate suitable for sea / air freight.

Components Included in Kit

Bladder Kit:

- 1 x PVC trucking bladder tank, 6,000 litres.
- 1 x Plastic groundsheet 0.5mm.
- 1 x Holdall bag.

Fittings Kit:

- 2 x 2" gate valves (female) brass (fitted to 2" outlet ports).
- 2 x 2" nipples, hex, BSP (male), GI (fitted to above).
- 2 x 2" hose couplings, BSP (female), MI (fitted to above).
- 2 x 2" hoses, 5 m long, transparent PVC medium duty (5 bar), max working pressure 5 bar burst 10 bar.
- 4 x 2" hose couplings, hositail MI (fitted to both ends of hoses).
- 4 x 2" hose clamps, jubilee type (fitted to above).
- 2 x Rolls PTFE tape 12mm wide, 30m.

Repair Kit:

- 1 x PVC repair patches material 1.0m x 0.5m.
- 1 x PVC glue "neoprene contact" 100 g tube.
- 1 x IATA approved container for PVC glue.
- 1 x Sand paper, wet and dry use, fine, n°120, A4 sheet.

Instruction, operating and maintenance manual shall be included in addition to spare parts lists.

Additional Notes / Resources

- The trucking bladder will require a suitable flatbed truck with at least 4m x 2.2m space, with a minimum carrying capacity of 6 tonnes and with side hooks for tying the webbing straps. Ensure the truck bed is swept clean and is free from sharp edges that may damage the bladder. Lay out the groundsheet where the bladder is to be positioned. Roll out the bladder tank, ensuring that tank outlets are positioned at the end of the truck and are accessible for opening and closing. Lay out the heavy-duty webbing straps and hook to truck base. Once the bladder is full the straps should be tightened down securely to prevent rolling and unbalancing of the truck when cornering.
- The trucking bladder should be used for water transportation and it is not advisable to be used as a static water point. A two inch hose is provided to facilitate rapid offloading into water reservoirs. Care should be taken to ensure the receiving water bladders are installed at a lower height than the height of the trucking bladder. Alternatively, either an earth ramp may need to be constructed alongside the water reservoir to facilitate offloading by gravity. If the trucking bladder is used to fill water reservoirs then the 2" diesel surface water pump should be ordered to assist offloading.

[Water Storage Manual – Oxfam \(PDF 4.2 MB\)](#)  
[Water Bladder Cleaning Instructions \(PDF 3.2 MB\)](#)

Note: last updated, April 2020

Item Application Sample



General Information and Description

Robust "onion shaped" collapsible and reusable water tanks with a self-supporting top ring and cover made from food grade PVC material suitable for drinking water storage in 10,000 litre and 30,000 litre sizes. Onion tanks are small, easily transportable and very quick to set up for short-term water provision typically in emergency settings. The large opening at the top makes onion tanks very suitable for batch water treatment (coagulation/flocculation) or for storing of raw or chlorinated waters. Kit is complete with groundsheet, basic fittings (control valves and fittings to allow connection to 32mm PE pipe), and repair kit. Kit does not include tapstands or pipework (these need to be ordered separately).

Technical Specifications

**Material:** UV resistant, mould and mildew resistant, food grade PVC coated polyester fabric (minimum 1100 g/m<sup>2</sup>) with thermal stability - 30°/+70°C. All materials used should be suitable for chlorinated drinking water.

**Reinforcement:** Water tank corners to be fitted with aluminium or plastic flanges for anchoring. Water tank inlet/outlet to be reinforced with a double layer of fabric. All seams to be either heat or high frequency welded. Outlets to be fitted with anti-chafe patch and flap.

**Outlets:** 2 x 75 mm (3") diameter BSP (male) threaded bolted flange outlet stub, made of aluminium, stainless steel, polypropylene or PVC, one port at each end of the water tank (for filling/inlet and discharging/outlet purposes). The ports are to remain horizontal once the tank is filled. The internal side of the outlets should be fitted with 2 x 75 mm (3") diameter BSP (female) threaded bolted flange stubs, also made of aluminium, stainless steel, polypropylene or PVC.

**Groundsheet:** Plastic sheet, minimum thickness 0.5 mm, must protrude over the 4 sides of the water tank by not less than 50 cm.

Weight, Volume and Packaging

	Gross weight:	Volume:	Dimensions:
10,000 litre	149 kg	1.18 m <sup>3</sup>	136 x 96 x 90 cm
30,000 litre	194 kg	0.48 m <sup>3</sup>	120 x 100 x 40 cm

**Packaging:** All the items shall be packed in a timber crate suitable for sea / air freight.

Components Included in Kit

Onion Tank Kit:

- 1 x PVC onion tank (quote either 10m<sup>3</sup> or 30m<sup>3</sup>).
- 1 x PVC cover with fittings to secure to tank in high winds.
- 1 x Plastic groundsheet 0.5mm.
- 1 x Holdall bag.

Fittings Kit:

- 2 x 3" gate valve (female) brass.
- 2 x 3" reducing bush, 3" BSP (male) to 1" BSP (female), GI.
- 2 x 32mm compression adapter 32mm - 1" BSP (male), PE.
- 2 x 32mm compression tee, PE.
- 2 x 3" nipple, hex, BSP (male), GI.
- 2 x Rolls PTFE tape 12mm x 30m.

Installation Kit:

- 2 x Pickaxes.
- 2 x Spades.
- 1 x Roll PVC barrier tape, 500m.
- 1 x Roll blue polypropylene rope, 50m.
- 1 x Spirit level 60cm.

Repair Kit:

- 1 x PVC repair patches material 1.0m x 0.5m.
- 1 x PVC glue "neoprene contact" 100 g tube.
- 1 x IATA approved container for PVC glue.
- 1 x Sand paper, wet and dry use, fine, n°120, A4 sheet.

Instruction, operating and maintenance manual shall be included in addition to spare parts lists.

Additional Notes / Resources

- The tank should be elevated to approximately 1.5m above the level of the tapstands to provide sufficient head for gravity feed. Options for elevating the tanks include earth mounds, oil drum platforms, wooden structures, or use of existing topography.
- Onion tanks have a tendency to roll and care must be taken to ensure the installation location is perfectly flat and level.
- Onion tanks are generally suited to short term emergency interventions. For longer term scenarios it is better to order Oxfam tanks or PE polytanks tanks instead.
- The tank should be protected from direct sunshine and should be properly cleaned, dried and folded before put back into storage.

[Water Storage Manual – Oxfam \(PDF 4.2 MB\)](#)

[Onion Tank Cleaning and Repair Instructions \(PDF 3.2 MB\)](#)

Note: last updated, April 2020

Item Application Sample



General Information and Description

Large cylindrical water tanks made of corrugated steel panels with a reinforced rubber liner. The tanks are easily transportable and quick to set up for emergency water provision and are very suitable for water treatment (coagulation/ flocculation) or for storing of raw or chlorinated waters. Kit is complete with basic fittings (3" control valves), repair kit, and roof kit to keep water free from dust and inhibit algal growth. Kit does not include tapstands or pipework (order separately).

	Height:	Diameter:	No. of Steel Panels:
11m <sup>3</sup>	2.3m	2.5m	18 x (1.5m x 0.8m)
45m <sup>3</sup>	1.5m	6.4m	14pcs (3.0m x 0.8m)
70m <sup>3</sup>	2.3m	6.4m	21pcs (3.0m x 0.8m)
95m <sup>3</sup>	3.0m	6.4m	28pcs (3.0m x 0.8m)

Technical Specifications

**Tank steels:** Corrugated galvanised curved steel sheets 0.8mm thick with minimum tensile strength of all panels 90kN including a safety margin of 25%. Steel sheets are drilled with 14mm holes along the edges to accept fixing bolts. Three steel sheets have additional 3" holes, fitted with blanking plates, to permit connection to 3" flange assemblies secured with 4 x 17mm bolts on a diameter of 146mm.

**Tank liner:** UV resistant, chlorine mould and mildew resistant, 1.25mm thick scrim reinforced EPDM synthetic rubber tank liner with thermal stability -30°/+70°C, suitable for potable water use, welded to fit tank size and allowing minimum 300 mm turndown on outside with eyelets spaced at 1 m centres around edge. Liner material is certified to US-EPA, NSF or EU national standards for not leaching into the water any component that may/might be of potential health risk.

**Tank cover:** Reinforced, conically shaped uPVC cover with brass eyelets for securing with rope. Centre pole supports the roof creating an adequate slope for runoff. Inspection / dosing hatch opening 500 mm diameter just above the tank edge with a 750 mm square flap top hinged above with eyelet at both bottom corners for tying down.

Weight, Volume and Packaging

	Gross weight:	Dimensions:
11m <sup>3</sup>	316 kg	153 x 86 x 60 cm
45m <sup>3</sup>	253 kg / 215kg *	298 x 88 x 56 cm / 147 x 79 x 71 cm
70m <sup>3</sup>	363 kg / 249kg *	298 x 88 x 57 cm / 147 x 71 x 82 cm
95m <sup>3</sup>	483 kg / 215kg *	298 x 88 x 58 cm / 147 x 71 x 92 cm
Roof Kit	83 kg	134 x 62 x 50 cm

\* two values provided for weights and dimensions of tank steels and tank liners

Components Included in Kit

**Steels Kit:** (quote either 11m<sup>3</sup>, 45m<sup>3</sup>, 70m<sup>3</sup> or 95m<sup>3</sup>).  
 1 x Set of corrugated steel panels 0.8mm with 14mm bolt holes.  
 1 x Set of 20mm long M10 round head bolts, nuts and washers.  
 2 x Roll of self-adhesive cloth based tape (gaffer), 50mm x 55m.  
 1 x Roll of rope, polypropylene, ultra-violet stabilised, 6mm x 50m.  
 6 x Steel pegs, 10mm Ø x 450mm long.

**Liner Kit:** (quote either 11m<sup>3</sup>, 45m<sup>3</sup>, 70m<sup>3</sup> or 95m<sup>3</sup>).  
 1 x Rubber (EPDM) liner 1.25mm thick suitable for potable water use (quote either 11m<sup>3</sup>, 45m<sup>3</sup>, 70m<sup>3</sup> or 95m<sup>3</sup>).  
 2 x Rolls of plastic split capping 25m (1 x 12mm Ø and 1 x 25mm Ø)

**Roof Kit:** (quote either 11m<sup>3</sup>, 45m<sup>3</sup>, 70m<sup>3</sup> or 95m<sup>3</sup>).  
 1 x Reinforced, conically shaped uPVC cover with 0.5m covered inspection opening, sewn hem and brass eyelets placed every 0.5m.  
 1 x 4" uPVC pole assembly consisting of: 1 x galvanized steel 0.8mm conically shaped ridge plate, 450mm Ø with 4" uPVC socket attached and drilled with 28 holes filled with 28 x 7.5m lengths of 6mm ultra-violet stabilised polypropylene rope; 1 x Galvanized steel 0.8mm round base plate, 600mm Ø with 4" uPVC socket attached.  
 4 x Sections of uPVC Pipe 4", 2 x 1.31m and 2 x 0.75m length.  
 3 x Unions uPVC 4"; 28 x Eye nuts M10.

**Fittings Kit:**  
 3 x 3" flange assembly comprising inner and outer threaded flanges with threaded 3" BSP pipe, synthetic rubber gaskets (x2), M16 steel studs (x4) on a diameter of 146mm, M16 nuts and washers (x8)  
 3 x 3" gate valves (female) brass.

**Installation Kit:**  
 2 x pickaxes, 2 x spades, 2 x Podger spanner 17mm open ended, 2 x Ratchet socket spanner M10, 2 x Flat headed screwdriver 10mm head, 1 x roll PVC barrier tape, 500m, 1 x roll blue polypropylene rope, 50m, 1 x spirit level 60cm, 2 x rolls PTFE tape 12mm x 30m.

**Repair Kit:**  
 1 x Rubber (EPDM) patch 1.0m<sup>2</sup> and 1 x roll patch tape 50mm x 10m  
 1 x Sand paper, wet and dry use, fine, n°120, A4 sheet.  
 1 x Repair kit comprising: 1m<sup>2</sup> uPVC, 1 roll of twine and 3 needles.

Additional Notes / Resources

- Tanks may be located to take advantage of local topography or may be raised using sandbags, steel liners, or other platforms.
- The largest 95m<sup>3</sup> tank is 3m high and requires the use of ladders for installation of the upper ring of steels, liner and roof structure.
- The uPVC roof is not designed to withstand snow falls and an alternative steel roof kit should be ordered in winter climates.

[Water Storage Manual – Oxfam \(PDF 4.2 MB\)](#)

[Liner Repair Instructions \(PDF 3.2 MB\)](#)

Note: last updated, April 2020

Item Application Sample



General Information and Description

Rigid water tank made from food grade low density polyethylene suitable for drinking water storage in 5,000 litres, 10,000 litres, 20,000 litres and 40,000 litre sizes. Poly tanks are easily transportable and very quick to set up for both short-term and long-term water provision. Poly tanks are suitable for batch water treatment (coagulation/flocculation) or for storing of raw or chlorinated waters. Smaller tanks may be used for water trucking operations, or several larger tanks may be joined together in one elevated location as part of a gravity fed water supply network. Kit is complete with basic lightweight fittings (inlet ball valve and outlet control valves). Kit does not include tapstands or pipework (these need to be ordered separately). Note that due to their size polytanks are generally a local or regional purchase item, rather than an international purchase item, and supply may be subject to the availability of manufacturers in the region.

Technical Specifications

**Material:** UV stabilised, mould and mildew resistant, food grade low density LDPE polyethylene with thermal stability -30°/+70°C. All materials used should be suitable for chlorinated drinking water. Materials should contain black or dark blue light proof dye to inhibit algae growth. Polytanks should come with a 5 year guarantee against defects and UV degradation (brittleness).

**Outlets:** Polytanks to be equipped with one 2" (50mm) PE (male BSP) threaded inlet positioned at the top of the tank, one 2" (50mm) PE (male BSP) threaded outlet positioned 15cm from the base of the tank, and one 2" (50mm) PE (male BSP) threaded drain positioned at the bottom of the tank. The inlet and outlet locations should be thickened and reinforced with additional material. A 450mm diameter manhole with cover should be provided on the top of the polytank to facilitate cleaning.

**Fittings:** Lightweight plastic fittings (float valve and ball valves) and flexible hose fittings should be used to reduce stress concentrations on the inlet and outlet regions. All fittings should be rated PN16.

Weight, Volume and Packaging

	Gross weight:	Height:	Diameter:
5,000 litre	100 kg	1.70m	2.08m
10,000 litre	200 kg	2.67m	2.48m
20,000 litre	400 kg	2.60m	3.80m
40,000 litre	700 kg	3.20m	4.33m

**Packaging** Generally no additional packaging is required however care should be taken when handling and transporting the polytanks to avoid scratching or puncturing.

Components Included in Kit

**Polytank Kit:**  
1 x LDPE polytank with 2" (50mm) BSP (male) inlet, 2" (50mm) BSP (male) outlet, 2" (50mm) BSP (male) drain, and 450mm top access hole with cover (quote either 5m<sup>3</sup>, 10m<sup>3</sup>, 20m<sup>3</sup> or 40m<sup>3</sup>).

**Fittings Kit:**  
2 x 2" globe valve (BSP female) PE PN16.  
1 x 2" BSP (male) float valve GI PN16.  
1 x 2" Socket BSP (female) PVC PN16.

**Installation Kit:**  
2 x Pickaxes.  
2 x Spades.  
1 x Roll PVC barrier tape, 500m.  
1 x Roll blue polypropylene rope, 50m.  
1 x Spirit level 60cm.  
1 x Roll PTFE tape 15mm x 10m

Additional Notes / Resources

- The polytank may need to be raised to provide sufficient head for gravity feed. Options for elevating the tanks include sandbags, brick and block plinths, wooden structures, or use of existing topography. There should be no tank overhang.
- Care should be taken when handling and transporting the polytank to ensure that it is not damaged. Small repairs may be made on site by patching and appropriate heat fusion equipment.
- The polytank is made from UV stabilised LDPE and may go brittle over time however its life can be extended by providing it with shading or locating it in the shade of trees.
- The polytank can be stressed at the inlet and outlet points if heavy and fixed fittings are used. It is better to use lightweight plastic ball valves and flexible hose fittings to reduce stresses in these areas.

[Water Storage Manual – Oxfam \(PDF 4.2 MB\)](#)  
[Polytank Cleaning and Repair Instructions \(PDF 3.2 MB\)](#)

Note: last updated, April 2020

**Item Application Sample**



**General Information and Description**

Tank fittings kits that contain a selection of 3" fittings which allow water tanks to be connected to each other when setting up water storage, treatment, pumping, or distribution facilities. The first kit is a basic package allow interconnectability. The second kit is designed to facilitate batch water treatment using two or three corrugated steel water tanks. Note that these kits require either 3" flexible reinforced hose or 3" layflat hose which needs to be ordered separately.

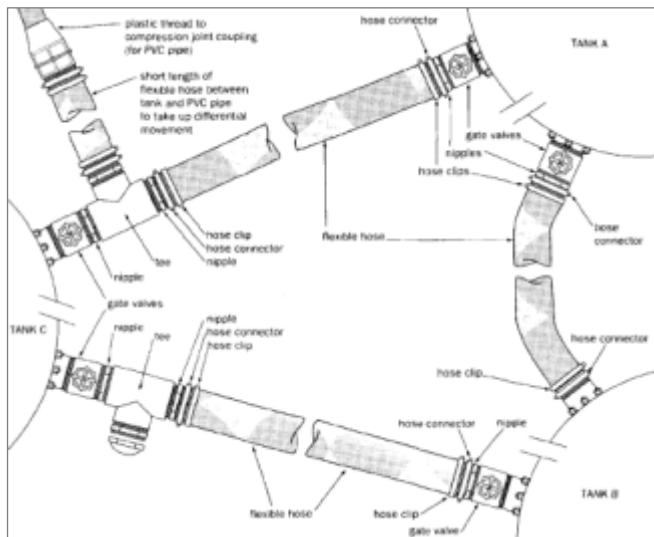

**Weight, Volume and Packaging**

	Gross weight:	Volume:	Dimensions:
Tank Fittings Kit	50 kg	0.14 m <sup>3</sup>	60 x 56 x 40 cm
Batch Fittings Kit	60 kg	0.18 m <sup>3</sup>	72 x 48 x 50 cm

**Packaging:** All the items shall be packed in a timber crate suitable for sea / air freight.

**Components Included in Kits**

**Tank Fittings Kit:**

- 2 x Tee, 3" BSP(F), GI
- 13 x Nipple, Hex, 3" BSP(M), GI
- 2 x End cap, 3" BSP(F), GI
- 10 x Coupling, Hose, 3" BSP(F), Brass
- 12 x Clip, Hose, 3", Bolted
- 2 x Adapter, Compression, 90mm
- 1 x Elbow, 90°, 3" BSP(F), GI
- 1 x Pipe, 90mm, uPVC, 500mm long, 3" BSP(M) thread at one end
- 2 x Valve, Gate, 3", Brass
- 5 Roll(s) Tape, PTFE

**Batch Treatment Fittings Kit:**

- 10 x Coupling, Hose, 3" BSP(M), MI
- 5 x Coupling, Hose, 3" BSP(F), MI
- 15 x Clip, hose, 3", Bolted
- 3 x Tee, Equal, 3" BSP(F), GI
- 7 x Elbow, 90°, 3" BSP(F), GI
- 7 x Nipple, Hex, 3" BSP(M), GI
- 2 x Valve, Gate, 3", Brass
- 10 x Roll(s) Tape, PTFE

**Additional Notes / Resources**

- Arranging the tanks in a ring allows all tanks to be filled and drained at the same time but also allows one tank to be taken out of service for cleaning or maintenance without affecting supply.

[Water Storage Manual – Oxfam \(PDF 4.2 MB\)](#)

[Water Distribution Manual – Oxfam \(PDF 4.2 MB\)](#)

Note: last updated, April 2020

# **SECTION THREE**

## **WATER TREATMENT**

Item Application Sample



General Information and Description

Flocculant/disinfectant sachets typically contain a combination of powdered flocculant that removes dirt particles and a disinfectant that destroys pathogens and leaves a residual for further protection. The product is rapidly mixed with water and is then left for 5 minutes (depending upon manufacturer) for flocs to form and settle at the bottom of the bucket. The treated water is then poured through a cloth to separate the floc from the clear potable water. Flocculant/disinfectant sachets are generally useful for short-term emergency household level water treatment where it is difficult to establish centralized water treatment (e.g. settings where the population is dispersed across a large area). Flocculant/disinfectant sachets should be used where water sources are turbid (e.g. surface water such as rivers, streams, lakes or unlined open wells). If the water to be treated is non-turbid (e.g. from springs or handpumps) then it is better to use chlorine tablets.

Example Instructions:

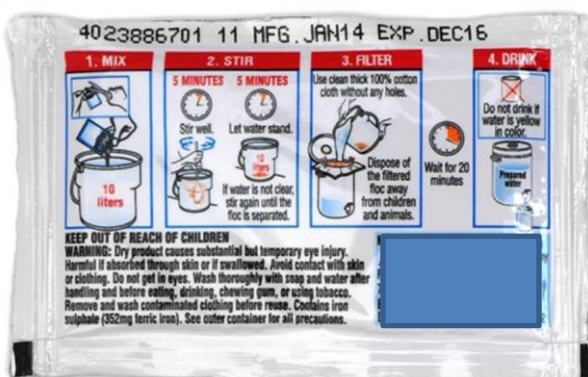

Example Instructions:



Components Included in Kit

Water Treatment Sachets:

1 x Box of water treatment sachets for 10 litres (6,000 sachets)

Water Treatment Sachet Household Kit:

Flocculant/disinfection sachets require additional household items for cutting, measuring, stirring, filtering, decanting, and storage. If the population does not have these items they should be sourced and supplied as a kit as follows:

- 1 x Scissors (sachets are made from rip-proof material).
- 2 x 14 litre plastic household bucket with lids.
- 1 x Wooden stirring spoon or stick (50cm).
- 1 x Straining cloth (1m<sup>2</sup>).
- 1 x Flyer illustrating key steps in local language.

Alternatively UNHCR and WASH actors should verify that these products are available at the household level.

Weight, Volume and Packaging

	Weight:	Volume:	Dimensions:
Sachets (6,000 pcs)	42 kg	0.25 m <sup>3</sup>	52 x 80 x 54 cm

Packaging: All items packed in a timber crate suitable for air freight.

Additional Notes / Resources

- A box of 6,000 sachets is sufficient to meet the needs of 1,000 people for one month taking into account sufficient quantity to treat drinking water only (4 litres per person per day) rather than treatment of water for bathing, laundering and cooking.
- The success of a household water treatment with flocculant/disinfectant sachets is fully dependent on the motivation of the refugee population to understand the product and use it. The intervention is most likely to succeed when the product that is being promoted is already familiar or known. The program should be closely tracked by monitoring a sample of household drinking water chlorine residual levels.
- If communities have never used flocculant/ disinfectant products before then UNHCR and WASH actors should ensure the first distribution of flocculant/ disinfection sachets is accompanied with a visual demonstration preferably in small groups.

[Example Instructions Flyer in English \(PDF 4.2 MB\)](#)  
[PUR Fact Sheet - CAWST \(PDF 4.2 MB\)](#)

Note: last updated, April 2020

Item Application Sample



General Information and Description

Water disinfection tablets are used to enable water disinfection at the household and institution level in the first phase of an emergency or for the longer term in situations where it is difficult to establish centralized water treatment (e.g. settings where the population is dispersed across a large area). Each tablet contains a quantity of NaDCC Sodium Dichloroisocyanurate and is added directly to a clean water storage container. After waiting 30 minutes the chlorine will have oxidized any pathogens, leaving a 0.6 mg/l residual chlorine, and water that should be safe to drink. Water disinfection tablets claim to give a 99.9999% reduction in bacteria, a 99.99% reduction in viruses and a 99.9% reduction in Cysts (Giardia) within 30 minutes, when used in non-turbid water. The larger 1.67g NaDCC tablets work identically to the smaller 67mg tablets and may be used in health posts and schools.

Tablet Size	Typical Application	Emergency Dosage	Normal Dosage:
67mg	Household	1 tablet per 10 litres	1 tablet per 20 litres
1.67g	Clinic, school	1 tablet per 250 litres	1 tablet per 500 litres

Weight, Volume and Packaging

The 67mg tablets come in strips of 10 tablets and the 1.67g tablets come in tubs of 200. Both types can be ordered as cartons or pallets.

	Tablets per Carton	Carton Weight:	Carton Dimensions:
67mg	16,000	6.6 kg	60 x 34 x 40 cm
1.67g	1,200 (6 tubs of 200)	4.8 kg	12 x 36 x 24 cm

	Cartons per Pallet:	Pallet Weight:	Pallet Dimensions:
67mg	28 cartons	185 kg	120 x 120 x 150 cm
1.67g	168 cartons	813 kg	120 x 120 x 150 cm

**Packaging:** All items packed in a reinforced cardboard box suitable for air freight. NaDCC is approved for all forms of transportation.

Additional Notes / Resources

- A box of 16,000 x 67mg tablets is sufficient to meet the needs of 2,500 people for one month taking into account sufficient quantity to treat drinking water only (4 litres per person per day) rather than treatment of water for bathing, laundering and cooking.
- Water disinfection tablets should be used where water sources have low turbidity i.e. < 10 NTU (e.g from springs, handpumps, lined wells, or piped supplies). If the water to be treated is turbid (e.g surface water such as rivers, streams, lakes or unlined open wells) then it is better to use flocculant/disinfectant sachets.
- The success of a household water treatment with disinfection tablets is fully dependent on the motivation of the refugee population to understand the product and use it. The intervention is most likely to succeed when the product that is being promoted is already familiar or known. The program should be closely tracked by monitoring a sample of household drinking water chlorine residual levels. To achieve this it is essential to order [chlorine residual pool testers](#).
- If communities have never used disinfection tablets before then actors should ensure the first distribution of is accompanied with a visual demonstration preferably in small groups.
- Note that there are a large variety of sizes of water disinfection tablets available on the international markets however only the 67mg size tablet should be used at the household level to avoid confusing the population.

[Example Instructions Flyer in English \(PDF 4.2 MB\)](#)  
[Example Safety Data Sheet \(PDF 4.2 MB\)](#)

Note: last updated, April 2020

Example Water Disinfection Tablet Instructions:

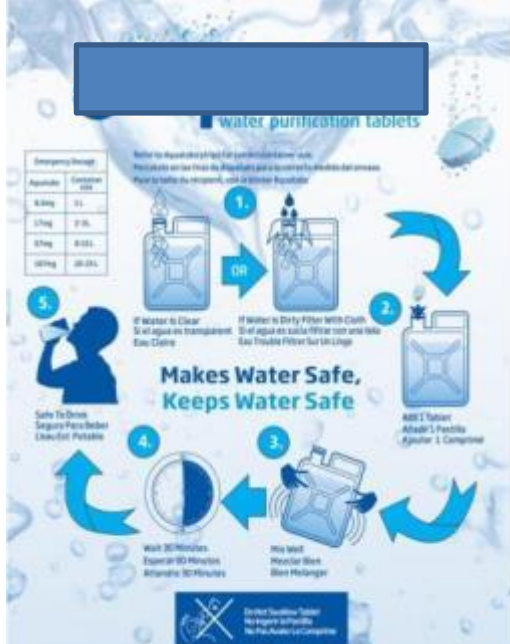





Item Application Sample



General Information and Description

Portable, inexpensive, compact household family water filter consisting of two 16 litre stackable plastic containers fitted with two candle type ceramic water filters. The filters should be capable of removing micro bacterial contamination up to 0.5µ. Output capacity expected to be between 10 and 80 litres per day depending on the raw water quality. Water is fed through the filters by gravity and the units require no additional power source. These types of filters are useful for household level water treatment in dispersed scenarios where it is not possible to set up centralized treatment and supply. The filters are useful in both emergency and longer-term settings.

Technical Specifications

**Plastic containers:** Two durable and stackable food grade 16 litre capacity HDPE/LLDPE plastic bodies with lids. Containers and lids should be durable enough to withstand the weight of water when fully filled (16kg). Lower plastic body to be fitted with a spring loaded plastic outlet tap. All materials used should be suitable for drinking water.

**Filters:** Two silver impregnated ceramic ('Sterasyl' type or equivalent) candle filter elements with a pore size 0.5µ should be pre-fitted to the upper plastic water container. The external dimensions of each filter element should be a minimum of 178mm (7") in length and 50mm (2") in diameter. The elements should be able to withstand cleaning at least 100 times with a soft brush. The elements should have at least the following filtering certification documentation:

**Filter removal efficiency:**

- 100.0% removal for 0.9µ and larger particles
- 99.99% removal for particles larger than 0.5µ
- 99.70% removal for particles larger than 0.3µ
- 98.00% removal for particles larger than 0.2µ
- 99.99% removal of Cryptosporidium, E-Coli, Vibro Cholera, Salmonella, and Typhi Shigella Disentaria.

Weight, Volume and Packaging

	Gross weight:	Volume:	Dimensions:
Pallet of 100	200 kg	1.88 m <sup>3</sup>	120 x 100 x 157 cm

**Packaging:** The plastic containers should be palletized and wrapped in heavy duty export carton. The candle filters should be individually bubble wrapped and packed in a timber crate to avoid breakages during transport.

Components Included in Kit

**Household Water Filter Kit (100 Units):**

- 200 x Ceramic candle filters, pore size 0.5µ, min 7"
- 100 x Food grade polypropylene container 16 litre capacity with lid, drilled to accept two filter candles
- 100 x Food grade polypropylene container 16 litre capacity with lids, drilled to accept tap
- 100 x Plastic tap assembly, suitable for drinking water.

Additional Notes / Resources

- The success of the household ceramic filter intervention is fully dependent on the motivation of the refugee population to use the filter unit, understand the limitations of the unit (especially filtration rates) and clean and take care of it. The intervention is most likely to succeed when the product is already familiar or known and it is possible to buy spare filter candles locally.
- The household filter unit should be assembled before distribution and the family instructed how to use and maintain the unit. An additional supply of soft nail brushes may be procured locally and distributed with the filter to facilitated cleaning.



- In locations where the source water is turbid the families should be taught how to settle or pre-filter the water to increase filter efficiency. This may be achieved by either plain sedimentation (leaving the water to settle and decanting), rapid filtration through a clean muslin cloth, or a combination of these techniques.
- Distribution of filter units alone does not necessarily guarantee the refugee population is using the units and actual use and filter condition should be tracked at the household level.

[Household Water Treatment and Safe Storage in Emergency Settings – UNHCR \(PDF 4.2 MB\)](#)

Note: last updated, April 2020

Item Application Sample



General Information and Description

Calcium hypochlorite (high test hypochlorite - HTH) is one of the strongest forms of chlorine used in refugee settings. When fresh the product contains up to 70% available active chlorine. Calcium hypochlorite may be procured in containers of various sizes however the following sizes are the most useful in refugee settings:

**450g tub:** The smaller 450g tubs can be used for decentralized water treatment (wells, handpumps etc.) or for disinfection purposes in clinics or other public institutions (floors, surfaces, equipment etc.).

**5kg tub:** The 5kg tub is the largest size that can be transported by air cargo. It can be used for bulk water treatment applications in emergency settings. One 5kg drum may be used to treat up to 1,000,000 litres of water (water for 2,000 people for one month).

**45kg drum:** The larger 45kg drums are useful for bulk water treatment for long term water supply. One 45kg drum may be used to treat up to 10,000,000 litres of water (water for 20,000 people for one month). Note that these drums cannot be transported by air cargo.

Handling and Storage

Handling and storage:

- HTH should be stored in airtight containers in a cool, dry, shaded location that is well ventilated and out of direct sunlight. The location should be secure and out of the reach of the general population and especially children. HTH is a strong oxidiser and may cause explosions if placed close to, or in contact with, combustible material.
- Over time HTH may slowly give off toxic and corrosive chlorine gas that is extremely harmful and should not be allowed to accumulate. Chlorine gas is heavier than air and care should be taken to prevent it leaking out under doors and filling low spaces (stair wells, basements). Chlorine gas is also highly corrosive and may damage other metallic equipment (e.g. pumps, tanks, or pipes) stored nearby.

Weight, Volume and Packaging

	Packing Configuration:	Pallet Weight:	Pallet Dimensions:
450g tub	9 tubs per box 90 boxes per pallet	365 kg	120 x 80 x 158 cm
5kg tub	60 tubs per pallet	300 kg	120 x 80 x 152 cm
45kg drum	16 drums per pallet	720 kg	120 x 80 x 157 cm

**Packaging:** Calcium hypochlorite is a hazardous material and requires proper transport certification for air and sea freight. For air freight the product needs to be secured in IATA approved packaging.

Safety

First aid measures:

- Exposure to chlorine can cause severe irritation to the skin and eyes and/or chemical burns. Immediately flush with large amounts of water for at least 15 minutes and seek medical attention.
- Inhalation of chlorine gases can cause choking, chest pain, impaired lung function and permanent lung damage. In the event of inhalation immediately move the victim to fresh air, support respiration and seek medical attention.

Additional Notes / Resources

- Calcium hypochlorite drums may lose up to 1% of their active chlorine per year depending on how they are stored. Generally speaking, chlorine should not be stockpiled beyond 3-5 years.
- If possible, calcium hypochlorite should be sourced in country as it is dangerous and costly to transport and requires additional safety packaging for air (IATA) and sea transportation.
- In all cases the granulated form of calcium hypochlorite is recommended over the powdered form as in certain circumstances the powdered form can be highly volatile.
- When handling or preparing chlorine solutions for water treatment or disinfection, staff should wear full personal protective equipment including eye and face protection, gloves, boots, overalls and a PVC apron. Keep containers tightly sealed. Store in a clean, dry well-ventilated area.
- If WASH programs intend to carry out bulk water treatment using calcium hypochlorite it is essential to order [chlorine residual pool testers](#) and possibly some form of chlorine dosing apparatus for example the [dosatron chemical doser](#).
- HTH powders should be kept away from sources of moisture. Staff should take care never to use a wet scoop to remove HTH from a drum as this can cause an explosion resulting in a fire.

[Chlorination: WEDC Technical Brief #46 – WEDC \(PDF 4.2 MB\)](#)

Note: last updated, April 2020

Item Application Sample



General Information and Description

Floating pot chlorinators allow a slow release of chlorine into a hand dug well or water reservoir. They are filled with slow dissolving chlorine tablets and can be adjusted by changing the number of open slots on the side of the chlorinator, as well as by varying the amount of tablets used in chlorinator. Floating pot chlorinators are particularly useful in settings where the majority of water provision is through hand dug wells.

Technical Specifications

**Floating chlorinator:** Durable plastic floating pot type chlorinator with adjustable dosing rate and plastic lid. All materials used should be suitable for extended contact with chlorine and should be suitable for use with drinking water.

Weight, Volume and Packaging

	Gross weight:	Volume:	Dimensions:
Pallet of 3	2 kg	0.05 m <sup>3</sup>	50 x 48 x 21 cm

**Packaging:** The floating chlorinators should be individually wrapped and packed in a durable tri-wall carton box to avoid breakages during transport.

Components Included in Kit

**Household Water Filter Kit:**  
3 x Plastic floating pot type chlorinators with adjustable dosing rate and plastic lids - 210mm diameter x 175mm height.

Additional Notes / Resources

- The water in the hand dug well or reservoir needs to have low turbidity for the chlorine treatment to be effective.
- It is essential that the floating pot chlorinators are properly adjusted and the water supply is not over-chlorinated or under-chlorinated. To achieve this it is essential to order [chlorine residual pool testers](#).
- The quantity of water that needs to be chlorinated is a function of the diameter and depth of the water source in addition to the abstraction and recharge rates.

[Repairing, Cleaning and Disinfection of Hand Dug Wells – Oxfam Technical Brief \(PDF 0.7 MB\)](#)

Note: last updated, April 2020



Item Application Sample



General Information and Description

This kit enables a chemical solution (e.g. a 1% flocculant or disinfectant solution) to be added to a raw water supply at the suction side of a centrifugal pump. The rate at which the chemical solution is added can be controlled by adjusting the dosing solution inflow ball valve. The dosing solution is mixed rapidly and effectively into the raw water by the pump impeller blades as it passes through the housing. The kit contains all necessary fittings to be used with 2", 3" or 4" suction hose. Note that the suction hose is not provided with the kit and needs to be ordered separately.

In most situations this kit will be used for dosing aluminium sulphate and so the kit is shipped with one 25kg sack (packed inside the drum).

Technical Specifications

**Plastic 200l drum:** UV resistant, durable, medium density polyethylene (MDPE) 200 litre water drum with tight fitting lid suitable for contact with drinking water. Plastic should have thermal stability - 30°/+70°C and should not deform if used in hot climates or left in direct sunlight. Lower ½" outlet to be reinforced and fitted with a ½" male plastic (MDPE) hose adaptor.

**Feed pipe and dosing assembly:** Feed pipe and dosing assembly to consist of a food grade, clear, flexible, reinforced, UV resistant 12mm PVC feed pipe equipped with a ½" PVC (PN6) metering globe valve and secured using jubilee clips. Main dosing "throat" to consist of a 4"GI tee with a 4" to 1" GI reducing bush branch at 90° to the main flow for the feed. The ½" feed pipe valve is connected to the dosing assembly via a 1" to ½" GI reducing bush connected to a 90° GI elbow. A series of reducing fittings allows both ends of the 4" GI tee to be attached to 2", 3" or 4" suction hosetail fittings (provided).

Weight, Volume and Packaging

<b>Gross weight:</b> 96 kg	<b>Volume:</b> 0.54 m <sup>3</sup>
<b>Dimensions:</b> 64 x 64 x 132 cm	
<b>Packaging:</b> All items packed in a sturdy timber crate suitable for sea / air freight.	

Printed operating and maintenance instructions shall be included in the kit in addition to a spare parts lists.

Components Included in Kit

Suction Side Doser Kit:

- 1 x Water tank, 210 litre MDPE, with lid fitted, with internal filter, outlet located in bottom of tank and on/off PVC ½" valve with threaded sockets (F)
- 4 x Pipe, Flexible, 12mm dia., with 4 jubilee clips
- 1 x Coupling, Hose, ½" BSP(M) to 12mm, PVC
- 1 x Valve, Ball, Metering, ½" BSP(F), PVC
- 1 x Coupling, Reducer, 1" to ½" BSP(M), GI
- 1 x Elbow, 90°, 1" BSP(F), GI
- 1 x Nipple, Hex, 1" BSP(M), GI
- 1 x Tee, Reduced branch, 4" BSP(F) to 1" BSP(F), GI
- 3 x Nipple, Hex, 4" BSP(M), GI
- 1 x Valve, Gate, 4" BSP(F), Brass
- 2 x Coupling, Hose, 4" BSP(F), Brass
- 2 x Clip, Hose, 4" Bolted
- 2 x Nipple, Reducer, 4" to 3" BSP(M), GI
- 2 x Coupling, Hose, 3" BSP(F), Brass
- 2 x Clip, Hose, 3" Bolted
- 2 x Nipple, Reducing, 4" to 2" BSP(M), GI
- 2 x Coupling, Hose, 2" BSP(F), Brass
- 2 x Clip, Hose, 2" Bolted
- 1 x Tape, Adhesive, Gaffer
- 4 x Tape, PTFE
- 1 x Aluminium Sulphate, 25kg

Additional Notes / Resources

- The kit can be used for dosing any form of chemical coagulant (aluminium sulphate solution) or disinfectant (chlorine solution). The unit is connected into the suction line directly before the centrifugal pump.
- The 200 litre drum allows sufficient storage of dosing solution for several days.
- The suction side doser only allows for a crude adjustment of the dosing flowrate using the metering feed valve. If a greater degree of control is required it is better to order the [proportional doser kit](#).

[OXFAM Water Supply Scheme for Emergencies \(PDF 4.2 MB\)](#)  
[OXFAM Guidelines for Water Treatment \(PDF 0.6 MB\)](#)

Note: last updated, April 2020

**Item Application Sample**



**General Information and Description**

This kit contains a proportional doser which enables a chemical solution (e.g. a 1% flocculant or disinfectant solution) to be added to a water supply pipe either directly in-line or on a bypass. The unit operates without electricity, using water pressure as the power source. Dosing is determined by the volume of flow so is not affected by variations in flow rate or pressure. The kit is pre-assembled and mounted on a metallic backing board and includes connections, a pressure regulator, a flow restrictor and a pressure gauge. The kit contains all necessary fittings to be used with a 32mm, 63mm or 90mm pipe and includes Accessories (to construct by-pass connections and install control valve)

**Technical Specifications**

**Proportional Chemical Doser:** Durable, self-priming, proportional chemical dosing pump with integrated mixing chamber for flows up to 3m<sup>3</sup>/hr and chemical injection rates of 0.2% to 2%. Housing and internal mechanisms manufactured from chlorine resistant materials and suitable for contact with drinking water. Dosing accuracy to within +/- 10%. Suitable for direct or bypass type installations.

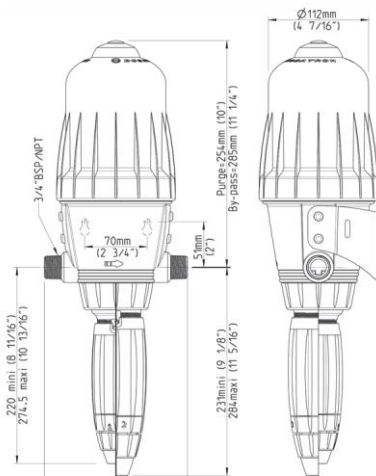

**Weight, Volume and Packaging**

**Gross weight:** 60 kg                      **Volume:** 0.4 m<sup>3</sup>  
**Dimensions:** 89 x 80 x 56 cm  
**Packaging:** All items packed in a sturdy timber crate suitable for sea / air freight.

**Components Included in Kit**

**Proportional Chemical Doser Assembly:**

- 1 x Dosing pump with PVDF housing, pressure regulator, flow restrictor and pressure gauge pre-assembled and mounted with connections on a metallic backing board

**Bypass Loop Accessories:**

- 1 x Valve, Gate, 3" BSP(F), Brass
- 2 x Adaptor, 90mm Compression x 3" BSP(M), PE
- 2 x Bush, Reducing, 3" BSP(M) x 2½" BSP(F), PE
- 2 x Adaptor, 2½" BSP(M) x 63mm Compression adaptor, PE
- 2 x Ferrule strap, 63mm, to 32mm compression coupling
- 2 x Ferrule strap, 90mm, to 32mm compression coupling
- 1 x Ferrule strap key
- 1 x Plasson wrench - for assembly of compression fittings
- 4 x Pipe inserts, 32mm
- 2 x Pipe inserts, 63mm
- 1 x Pipe, MDPE, 32mm, 4m length
- 1 x Insulation material and strapping (pack)

**Spare Parts:**

- 1 x Seal Kit

Instruction, operating and maintenance manual shall be included in addition to spare parts lists.

**Additional Notes / Resources**

- The dosing unit supplied with this kit can be used directly in-line with flows from 10 litres/hour to 3,000 litres/hour. For larger flows it is recommended the unit is installed on a bypass (accessories to construct the by-pass connections are included in the kit)
- The injection rate is set by adjusting the scale at the base of the unit. The amount of injected concentrate is proportional to the amount of water coming into the doser: i.e. adjustment at 1% = 1:100 = 1 volume of concentrate + 100 volumes of water. The dosing unit supplied with the kit can be adjusted to inject from 0.2% (1:500) to 2% (1:50).
- The dosing unit should not be used in cold climates or where the water temperature may drop below 5°C.

[Chlorinating Small Water Supplies: A Review of Gravity Powered and Water-Powered Chlorinators - WEDC \(PDF 4.6 MB\)](#)

Note: last updated, April 2020

Item Application Sample



General Information and Description

Aluminium Sulphate is one of the most common chemicals used for bulk water treatment of turbid surface waters in refugee settings. The chemical accelerates the coagulation of particulate matter together into flocs, speeding up the natural sedimentation process. Aluminium Sulphate is a low-cost natural and widely-available product and can be found on the local markets in most countries. It is generally used in large quantities for water treatment and local purchase is recommended where available. During emergencies, an initial supply may be sent by air to allow water treatment activities to start immediately. Aluminium Sulphate is available in powder, granular or stone chips form. The granular form is recommended. Aluminium Sulphate is available in 25kg and 50kg sacks.

Technical Specifications

Aluminium sulphate 17-18%  $Al_2O_3$  technical iron-free, in granules, in 25kg or 50kg PP (polypropylene) bags. Granule size 33% 1 to 5mm

Handling and Storage

Handling and storage:

- Aluminium Sulphate should be stored on wooden pallets in polypropylene sacks in a cool, dry location that is well ventilated and out of direct sunlight. The location should be secure and out of the reach of the general population and especially children.
- Aluminium sulphate powder is highly irritating for eyes, respiratory system and skin. Appropriate personal protective equipment should be worn by workers when loading, unloading and storing. This includes overalls, boots, safety glasses, PVC or rubber gloves and a dust respiratory mask.
- When handling or preparing Aluminium Sulphate solutions for water treatment, staff should wear full personal protective equipment including eye and face protection, gloves, boots, overalls and a PVC apron.

Weight, Volume and Packaging

	Packing Configuration:	Pallet Weight:	Pallet Dimensions:
25kg sacks	40 sacks per pallet	1033 kg	131 x 108 x 90 cm
50kg sacks	20 sacks per pallet	1012 kg	131 x 108 x 90 cm

**Packaging:** Aluminium Sulphate should be packed in strong, durable polypropylene sacks and securely stacked and pallet-wrapped onto wooden or plastic euro pallets for transportation. Aluminium Sulphate is not classed as a dangerous substance for transportation and does not require additional safety packaging.

Safety

First aid measures:

- Exposure to strong Aluminium Sulphate solutions can cause severe irritation to the skin and eyes and/or chemical burns and/or vomiting. Immediately flush with large amounts of water for at least 15 minutes and seek medical attention.
- Inhalation of aluminium sulphate powder can cause irritation of the nose, mouth and lungs. In the event of inhalation immediately move the victim to fresh air, support respiration and seek medical attention.
- Aluminium Sulphate is not flammable and is stable under normal conditions.

Additional Notes / Resources

- Alum Sulphate has a narrow effective pH operating range of pH 6.0 to 8.0. In some cases it may be necessary to adjust the raw water pH so that it falls within the effective operating range of the chemical coagulant. A [pool tester](#) should be ordered to monitor the pH levels of the treated water.
- The optimum dosing rate of Aluminium Sulphate for the raw water will depend upon the nature of the particles suspended in the water, the type of coagulant and pH of the raw water. The lowest effective should be determined by a jar test. The procedure can be found in the [UNHCR WASH Manual](#).
- UNHCR field staff and their partners must ensure that all water supplies that are treated using chemicals are tested for treatment chemical carry over. An [aluminium water testing kit](#) should be ordered to monitor the quality of the water. WHO guidelines recommend that aluminium should be no greater than 2mg/l.
- The Aluminium Sulphate solution should be rapidly and uniformly mixed into the raw water ideally before the water enters a pumping unit (mixing is achieved by the impellor blades) or at the inlet to the mixing tank where the flow is turbulent. Ideally coagulant addition should be carried out using a correctly calibrated [suction side doser](#) or [proportional doser](#).
- In some local markets Aluminium Sulphate may only be available as stone chip form rather than granular or powder form. These chips are not used to make solutions but are used to dose the water directly by running the water through a correctly sized dosing cage filled with the chips.
- Sludge accumulated from chemical coagulants has a high aluminium content. In all contexts, UNHCR field staff and WASH actors must ensure that all water treatment sludges are dewatered in shallow basins, dried into cake, and disposed of safely in a landfill where the impact on the environment can be controlled, minimized and monitored.

[OXFAM Water Supply Scheme for Emergencies \(PDF 4.2 MB\)](#)  
[OXFAM Guidelines for Water Treatment \(PDF 4.6 MB\)](#)

Note: last updated, April 2020



Item Application Sample



General Information and Description

Portable and versatile compact water treatment unit capable of producing up to 4m<sup>3</sup>/hr of drinking quality water from surface water sources such as rivers lakes and ponds. The treatment unit is generally useful for first phase emergency response interventions.

Technical Specifications

Portable, light weight compact water treatment unit comprised of the following stages and mounted on two separate galvanized skids:

**Diesel Driven Water Pump:** Single stage centrifugal self-priming 2" pump close coupled to a single cylinder 4 stroke air-cooled diesel engine capable of developing a duty of 4m<sup>3</sup>/hr at 25m head with 3600rpm. Pump fitted with a floating raw water intake.

**Pre-Chlorination:** Pre-chlorination doser pump unit configured for direct dosing with 1% calcium hypochlorite solution.

**Assisted Sedimentation:** Coagulant doser pump unit configured for direct dosing with 1% aluminium sulphate solution Flocculation unit allowing sufficient contact time for creation and sedimentation of flocs.

**Filtration:** Multiple filtration units including 25m<sup>3</sup> / (h.m<sup>2</sup>) sand filter, 25 and 5 microns filters (disposable element type) and 25m<sup>3</sup> / (h.m<sup>2</sup>) activated carbon filter. The filters are complete with back wash piping, valves, manometers and controls.

**Post-Chlorination:** Post treatment chlorine disinfection doser pump unit to guard against contamination during storage.

The water treatment unit is autonomous powered by means of the motor pump supplied with the unit. The complete water treatment unit is "skid-mounted" for transportation on the back of a pick-up.

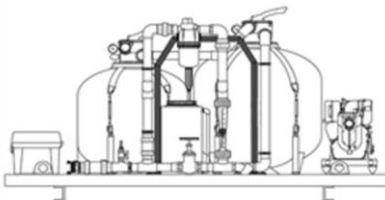

Weight, Volume and Packaging

	Gross weight:	Volume:	Dimensions:
Crate 1	288 kg	1.12 m <sup>3</sup>	120 x 82 x 150 cm
Crate 2	250 kg	1.02 m <sup>3</sup>	120 x 78 x 150 cm

**Packaging:** All the items shall be packed in a timber crates suitable for sea / air freight.

Components Included in Kit

Pumpset:

- 1 x Diesel engine, 7HP self-priming diesel motor pump, 4m<sup>3</sup>/hr at 25m head and 3600rpm
- 1 x Water suction hose 2" reinforced plastic flexible medium duty, max working pressure 3.5 bar burst 10 bar equipped with floating strainer and non-return valve (pre-fitted by the supplier).
- 1 x Pre-filtration unit max particule size 1mm

Sand Filter:

- 1 x Rapid sand filter unit installed inside 450mm dia. food grade abrasion resistant HDPE drum with filtration speed 25m<sup>3</sup> / (h.m<sup>2</sup>) and equipped with 6 way multiport valve and manual backwash and rinse. 1" output drain with strainer to allow filter draining and 2" output drain to allow mass filtration draining. Maximum pressure 2.5 bars, pressure test 4 bars.

Activated Carbon Filter:

- 1 x Activated carbon filter unit installed inside 450mm dia. food grade abrasion resistant HDPE drum with filtration speed 25m<sup>3</sup> / (h.m<sup>2</sup>) and equipped with 6 way multiport valve and manual backwash and rinse. 1" output drain with strainer to allow filter draining and 2" output drain to allow mass filtration draining. Maximum pressure 2.5 bars, pressure test 4 bars.

Automatic Dosing Units:

- 2 x Automatic dosing units with PVDF housing
- Supplied with all necessary hoses with quick release fittings for connection between components, consumables for 6 months operation for 5,000 people, detailed operation handbook, and maintenance kit for motor pump and dosing pumps.

Additional Notes / Resources

- The water treatment unit is rated at 4m<sup>3</sup>/hr but may produce significantly less water if the raw water is heavily contaminated.
- The unit is capable of producing drinking water free from physical and bacteriological contamination however the unit is not capable of removing dissolved mineral or industrial contamination, such as fluoride, arsenic, hydrocarbons, chemical wastes, etc.
- Compact water treatment units require expertise to set-up, operate and maintain. They are useful during the initial emergency phases of a refugee scenario, however they may not be appropriate for the post-emergency phases where WASH actors should aim to use simpler water treatment techniques that do not require imported spare parts and specialist expertise.

[OXFAM Water Supply Scheme for Emergencies \(PDF 4.2 MB\)](#)  
[OXFAM Guidelines for Water Treatment \(PDF 4.6 MB\)](#)

Note: last updated, April 2020

# **SECTION FOUR**

## **WATER DISTRIBUTION**



**Item Application Sample**



**General Information and Description**

A rapidly installed, durable, light-weight, water distribution kit comprising a tap stand with 6 self-closing taps and an installation tools kit. The tapstand can be used with additional water supply infrastructure (bladders, tanks, pumps, pipes) to deliver water to up to 1,500 people during an emergency response. The tapstand should be installed in a safe area, where people can queue for water collection. Waste-water drainage is essential to keep the area clean. The kit includes a number of fittings to allow the tapstand to be connected directly to a water bladder or to a HDPE water network. Note that water bladders, tanks, and pipes are not included in the kit and need to be ordered separately.

**Technical Specifications**

**Tapstand Frame:** Galvanized steel 40mm x 40mm hollow section frame fitted with: 1 x 1½" inlet BSP (male) pipe, 4 x 1" BSP (female) sockets angled to receive 4 x leg pieces, and 6 x ¾" threaded outlets. Frame to include four galvanized 1" Ø steel legs x 1m long with one end threaded to fit frame and other equipped with a drilled plate for holding down purposes. All tapstand components to be hot dipped galvanized internally and externally to BS EN ISO 1461:2009 with all threading carried out after the galvanisation process, using potable grade cutting oil. All parts supplied should be ready for immediate use, with all debris from the machining process removed from the internal water passages before packing.

**Taps:** Six simple, lightweight, robust, aluminium, hand-operated, self-closing taps proven to work equally well in either high pressure or low pressure settings. The taps should firmly close automatically when not in use to prevent water wastage through constant dripping. The taps should be capable of providing at least 14 litres of water per minute at 1.0m head. Taps to be equipped with a ¾" BSP (female) inlet connection.

**Additional Notes / Resources**

- One tapstand can serve up to 1,500 people (1 tap per 250 persons) during the first phase of an emergency response however as soon as possible more tapstands should be installed to reduce the coverage to 1 tap per 100 persons (600 people).
- The tapstand should be installed in a safe area, where people can queue for water collection. Waste-water drainage is essential to keep the area clean. The distribution area should be levelled and a concrete apron installed beneath the distribution stand.
- The tapstand should be thoroughly flushed with water before fitting any of the taps.
- The height of the taps should be at least 1.0m below the level of the water bladder or tanks in order to provide sufficient head for gravity feed.

[Water Scheme Scheme for Emergencies – Oxfam \(PDF 4.2 MB\)](#)

**Components Included in Kit**

**Tapstand Kit:**

- 1 x Hollow section frame, 40mm x 40mm section, fitted with: Inlet in centre of one side to connect 1½" BSP(M) pipe, (x4) 1" BSP (F) sockets angled to receive leg pieces, (x6) ¾" threaded outlets
- 6 x Nipple, Barrel, ¾" BSP(M) x 300 mm, GS - for taps
- 4 x Frame legs, 1" Ø x 1m long, GS - one end threaded to fit frame and other with foot plate
- 1 x Nipple, Barrel, 1½" BSP(M) x 600mm, GS - for inlet
- 4 x Coach bolt and nut, M10 x 100mm long with nut
- 4 x Coach screw, ¾" x 3" long - for mounting on timber frame
- 2 x PTFE tape (rolls)
- 6 x Valve (Tap), Evenflow type, ¾" BSP(F), Aluminium
- 2 x End cap, ¾" BSP(F), GI
- 1 x Adapter, 32mm Compression x 1" BSP(M), PE
- 1 x Tee, Reduced branch, 2"- 1½" BSP(F), GI
- 1 x End Plug, 2" BSP(M), GI
- 1 x Bush, Reducing, 2" x 1" BSP(M-F), GI
- 1 x Adapter, 50mm Compression x 2" BSP(M), PE
- 1 x Guillemin half coupling x 2" BSP(M), without locking ring, Aluminium

**Tapstand Connection Kit:**

- 1 x 6m length of plasticized 50mm diameter PVC abrasion resistant hose, ozone and weather resistant, smooth bore, fitted with a shock resistant rigid PVC spiral, each end fitted with 50 mm hosetail Guillemin half couplings secured with two jubilee clips.

**Tapstand Installation Kit:**

- 2 x Pickaxes 7lb with wooden shaft.
- 2 x Spades with straight 54" wooden handle.
- 2 x Stilson pipe wrenches 18"
- 1 x Roll PVC barrier tape, 500m.
- 1 x Roll blue polypropylene rope, 50m.
- 1 x Spirit level 60cm.
- 2 x Guilleman wrench 20-65 mm

Installation and operating manual shall be included in addition to spare parts list.

**Weight, Volume and Packaging**

<b>Gross weight:</b>	28 kg	<b>Volume:</b>	0.05 m <sup>3</sup>
<b>Dimensions:</b>	104 x 44 x 11 cm		
<b>Packaging:</b>	The water distribution kit should be disassembled and the parts and installation tools packed in a sturdy timber crate suitable for sea / air freight.		

Note: last updated, April 2020



Item Application Sample



General Information and Description

100m of lay-flat PVC water hose in 25m lengths equipped with hose couplings. The hoses can be quickly used for medium pressure water transportation applications. The ability to roll the hoses into a compact size and their quick set-up lends itself to emergency water responses. The hoses are ideal for use when speed is required and installations are to be temporary.

Technical Specifications

Lay-flat hose (flexible pipe) made of an inner tube of food grade SBR (Styrene Butadiene Rubber) with reinforcing braid in polyester and external coating in UV resistant acrylic. The pipe should be capable of withstanding a short length burst pressure of up to 20 bar and a service pressure of 9 bar in temperatures from -15°C to +70°C. The pipe is supplied in lengths of 25 meters with Guillemin aluminium couplings on both ends; complete with the required washers, locking ring and hose clips.

Components Included in Kit

2" Layflat Hose Kit:

- 4 x Hose, lay flat, 2", 25 m long, PVC
- 8 x Guillemin half couplings DN50 2" (male hose-tail), with locking rings, Aluminium, (fitted to each end of lay flat hose)
- 8 x Hose clips, bolted, (pre-installed to secure Guillemin couplings)

3" Layflat Hose Kit:

- 4 x Hose, lay flat, 3", 25 m long, PVC
- 8 x Guillemin half couplings DN75 2" (male hose-tail), with locking rings, Aluminium, (fitted to each end of lay flat hose)
- 8 x Hose clips, bolted, (pre-installed to secure Guillemin couplings)

Weight, Volume and Packaging

	Gross weight:	Volume:	Dimensions:
2" Layflat Hose Kit	43 kg	0.16 m <sup>3</sup>	61 x 61 x 42 cm
3" Layflat Hose Kit	62 kg	0.27 m <sup>3</sup>	120 x 60 x 42 cm
Packaging:	All the items shall be packed in a timber crate suitable for sea / air freight.		

Additional Notes / Resources

- Lay flat hoses should only be used for short-term temporary installations during a first phase emergency response. The water supply infrastructure should be upgraded as soon as possible.
- Lay flat hoses can be easily damaged or vandalized. It is useful to order additional hose tail couplings so that damaged sections can be removed and the pipe reconnected.

Note: last updated, April 2020

Item Application Sample



General Information and Description

100m of PVC spiral hose in 25m lengths equipped with hose couplings. The hoses can be quickly used for medium pressure water transportation applications. They are also excellent for suction applications and are particularly suited for excreta slurry pumping. Their durability and ability to roll the hoses into a compact size and their quick set-up lends itself to emergency response use when speed is required.

Technical Specifications

Heavy duty, UV resistant, flexible PVC spiral hose with smooth inner bore and hardened PVC spiral helix for increased crush and abrasion resistance. The pipe should be capable of operating in temperatures from -25°C to +60°C withstanding burst pressure of up to 9 bar and a service pressure of 6 bar. Resistance to vacuum at 20°C should be at least 90%. The pipe is supplied in lengths of 25 meters with Guillemín aluminium couplings on both ends; complete with the required washers, locking ring and hose clips.

Components Included in Kit

2" Spiral Hose Kit:

- 4 x Spiral hose 2", 25 m long, PVC
- 8 x Guillemín half couplings DN50 2" (male hose-tail), with locking rings, Aluminium, (fitted to each end of lay flat hose)
- 8 x Hose clips, bolted, (pre-installed to secure Guillemín couplings)

3" Spiral Hose Kit:

- 4 x Spiral hose 3", 25 m long, PVC
- 8 x Guillemín half couplings DN75 2" (male hose-tail), with locking rings, Aluminium, (fitted to each end of lay flat hose)
- 8 x Hose clips, bolted, (pre-installed to secure Guillemín couplings)

Weight, Volume and Packaging

	Gross weight:	Volume:	Dimensions:
2" Spiral Hose Kit	90 kg	0.16 m <sup>3</sup>	80 x 80 x 80 cm
3" Spiral Hose Kit	120 kg	0.27 m <sup>3</sup>	95 x 95 x 95 cm

**Packaging:** All the items shall be packed in a timber crate suitable for sea / air freight.

Additional Notes / Resources

- Spiral hose should only be used for short-term temporary installations during a first phase emergency response. The water supply infrastructure should be upgraded as soon as possible.
- Spiral hoses can be easily damaged or vandalized. It is useful to order additional hose tail couplings so that damaged sections can be removed and the pipe reconnected.

Note: last updated, April 2020

**Item Application Sample**



**General Information and Description**

50m coils of HDPE pipe for construction of drinking water distribution networks. Can be laid in unstable soil conditions above or below ground. Their durability and quick set-up lends itself to both emergency and long term settings. Note that pipe cutting equipment, butt-welding equipment and pipe fittings (either compression or electrofusion) should be ordered separately.

**Technical Specifications**

High Density Polyethylene (HDPE) water distribution pipe manufactured in accordance with ISO4427:1996/EN12201-2:2003. Non-toxic, suitable for drinking water manufactured from 100% virgin pellets high density polyethylene (60 to 80% degree of crystallinity), protected from ultra-violet sunlight and atmospheric oxygen (carbon black or blue), in compliance with national and international food regulations, designed for a service life of 50 years at 23 degrees Celsius. Can be joined by using compression/quick-coupling polypropylene fittings, or can be butt-welded by hot plate. Flexible, supplied in coils with two (2) polypropylene couplings per each coil.

Outside Diameter (OD)	Standard Dimension Ratio (SDR)	Pressure Rating (PN)
32mm HDPE Pipe	PE80 SDR11	12 Bar
63mm HDPE Pipe	PE80 SDR11	12 Bar
90mm HDPE Pipe	PE100 SDR11	12 Bar

**Weight, Volume and Packaging**

	Gross weight:	Volume:	Dimensions:
32mm HDPE Pipe	14 kg	0.19 m <sup>3</sup>	100 x 100 x 19 cm
63mm HDPE Pipe	53 kg	0.94 m <sup>3</sup>	190 x 190 x 26 cm
90mm HDPE Pipe	106 kg	1.58 m <sup>3</sup>	230 x 230 x 30 cm

**Packaging:** Coiled and strapped suitable for sea / air freight.

**Additional Notes / Resources**

- HDPE pipe is generally for use below ground however it is UV stabilised and can be used for several years above ground without serious problems of UV degradation.
- In most regions local purchase of water pipes may be advantageous and significantly cheaper. However, if local sources are used, consider the pressure rating required, quality and consistency of the materials, availability of suitable fittings - paying particular attention to the jointing system. Before purchase ensure that any water pipework has been correctly stored and has not been excessively exposed to UV light.

Note: last updated, April 2020

# **SECTION FIVE**

## **WATER QUALITY TESTING**

Item Application Sample

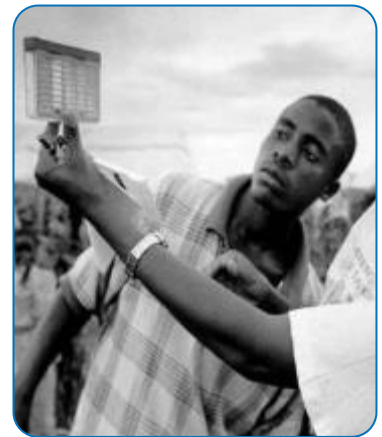

General Information and Description

The pooltester is an easy to use simple colour comparator tool for measuring free residual chlorine, total chlorine and pH of water samples. This kit can be used for surveillance and monitoring of water quality after treatment, i.e. free chlorine residual content in pipelines, in water storage tanks, in treatment plants, or at the consumer level. This kit is available as an individual tester or as boxes of 10. Each pool tester is supplied with sufficient reagents to carry out 20 tests. Additional boxes of 250 DPD1, DPD3 or Phenol Red tablets should be ordered at the start of a new programme.

Technical Specifications

**Pooltester:**

Transparent plastic (poly acrylate) water testing kit with one colorimetric scale for pH and two colorimetric scales for free and total chlorine residual, enabling both low and high levels of chlorine to be monitored. The pooltester and consumables for 20 tests are packed together in a protective plastic case to constitute an integrated kit, including the instructions for use. Pooltester measuring ranges as follows:

Chlorine Low Range: 0.1, 0.3, 0.4, 0.5, 0.6, 0.7, 0.8, 1.0 mg/l  
Chlorine High Range: 0.6, 1.0, 1.5, 2.0, 3.0, 4.0, 5.0, 6.0 mg/l  
pH: 6.8, 7.0, 7.2, 7.4, 7.6, 7.8, 8.0, 8.2 mg/l

**DPD No. 1 pack of 250 tablets:**

DPD No. 1 rapid dissolving tablets, photometer grade, for testing of drinking water for free chlorine for ranges of 0 to 10 mg/litre.

**DPD No. 3 pack of 250 tablets:**

DPD No. 3 tablets rapid dissolving tablets, photometer grade, for testing of drinking water for combined chlorine from 0 - 10 mg/litre.

**Phenol red pack of 250 tablets:**

Phenol red tablets rapid dissolving tablets, photometer grade, for testing of drinking water for pH for ranges of 6.8 to 8.4 mg/litre.

All tablets have expected shelf life of 10 years.

Weight, Volume and Packaging

	Weight:	Volume:	Dimensions:
Pooltester Kit	140 g	484 cm <sup>3</sup>	11 x 11 x 4 cm
DPD No.1 (250 tablets)	60 g	360 cm <sup>3</sup>	9 x 8 x 5 cm
DPD No.3 (250 tablets)	60 g	360 cm <sup>3</sup>	9 x 8 x 5 cm
Phenol Red (250 tablets)	60 g	360 cm <sup>3</sup>	9 x 8 x 5 cm

**Packaging:** Packed within a durable sealed cardboard carton suitable for sea / air freight. Due to the small size of cartons they may be mixed in with larger crates.

Components Included in Kit

**Pooltester Kit:**

- 1 x Pooltester water testing kit for pH, free and total chlorine residual (low and high levels in a protective plastic case)
- 2 x Strips of DPD No.1 tablets (20 tablets in total) for testing drinking water for free chlorine for ranges of 0 to 10 mg/litre
- 2 x Strips of DPD No.3 tablets (20 tablets in total) for testing drinking water for combined chlorine from 0 to 10 mg/litre
- 2 x Strips of phenol red tablets (20 tablets in total) for testing drinking water for pH for ranges of 6.8 to 8.4 mg/litre

**DPD No.1 additional consumables pack of 250 tablets:**

- 25 x Strips of DPD No.1 tablets (10 tablets per strip – 250 tablets in total) for testing drinking water for free chlorine for ranges of 0 to 10 mg/litre

**DPD No.3 additional consumables pack of 250 tablets:**

- 25 x Strips of DPD No.3 tablets (10 tablets per strip – 250 tablets in total) for testing drinking water for combined chlorine for ranges of 0 to 10 mg/litre

**Phenol red pack additional consumables of 250 tablets:**

- 25 x Strips of phenol red tablets (10 tablets per strip – 250 tablets in total) for testing drinking water for pH for ranges of ranges of 6.8 to 8.4 mg/litre

Additional Notes / Resources

- Pooltesters are useful in all emergencies where drinking water is treated using chlorine related products. Bulk water treatment operations should ensure that there is a free chlorine residual of at least 0.2mg/l at the point of collection at all times.
- If coagulation and flocculation are used the pooltester may also be used to check that the raw water pH is suitable for optimum treatment with aluminium sulphate.
- If water is treated at the household level using water disinfection tablets then a large number of pooltesters may be required for the monitoring programme.
- The pooltester is used by dipping the unit in the water to be tested, adding a DPD No.1 and phenol red tablet to the correct chambers, replacing the lid, inverting the tester until the tablets have fully dissolved and reading the result from the colour scale(s).
- The total chlorine level can be found by adding an additional DPD No.3 tablet to the sample containing DPD 1. The combined chlorine value is found by subtracting the free chlorine value from the total chlorine value. Monitoring of combined chlorine (mono and dichloramines) is useful as it has a strong and unpleasant chlorine smell and deter use.
- It should be noted that if DPD No. 3 tablets are employed, the user should ensure a proper cleaning of the test cell and lid after each test to avoid false readings.

Note: last updated, April 2020

**Item Application Sample**



**General Information and Description**

Portable water microbiological testing kit for measuring total coliforms and faecal coliforms in the field via the membrane filtration process. The unit has an internal incubator powered by a rechargeable battery which can provide power for up to five cycles of incubation without mains electricity. The kit is packed into a robust portable case and is capable of analyzing water sources on-site. The kit includes a turbidity tube, a pooltester, and consumables for 200 bacteriological tests.

**Technical Specifications**

**Membrane Filtration Unit:**

The vacuum membrane filtration unit consists of a aluminium collection flask, sampling cup plus bronze disc, gaskets and o-rings, as well as a pistol grip vacuum pump and set of accessories for the proper handling of samples including a pad dispenser unit, tweezers, dropping pipettes, plastic bottles, hand lens, lighter and lubrication grease, the unit is compatible with 0.45 µm pore size membrane filters (supplied with kit).

**Incubator Unit:**

The portable incubator has dual temperature settings of 37°C and 44°C (37°C for the analysis of total coliform or 44°C for faecal coliform) and is powered by an external 12V supply. The incubator compartment can accommodate up to 20 x 47mm alum petri dishes supplied in racks for easy compartment loading. The temperatures are preferably displayed on a LCD with an indication for low battery. The incubator has a timer facility that logs the incubation period in case of power failure. The incubator can be run from internal rechargeable battery, 110/220 V mains or 12 V DC supply such as vehicle battery or solar panel. If the mains supply fails the internal battery should automatically switch on. The unit should be supplied with all necessary electrical leads. The battery should be capable of 5 incubation cycles between recharges.

**Chlorine and pH:**

Transparent plastic (poly acrylate) pooltester type colorimeter with one colorimetric scale for pH and two colorimetric scales for free and total chlorine residual, enabling both low and high levels of chlorine to be monitored.

**Turbidity:**

Two part plastic turbidity tube, 26" long with 0 - 500 NTU marked on the side allowing visual measurement of water turbidity (units NTU).

**Weight, Volume and Packaging**

**Gross weight:** 25 kg                      **Volume:** 0.04 m<sup>3</sup>  
**Dimensions:** 41 x 24 x 34 cm  
**Packaging:** The unit should be packed in a sturdy cardboard carton suitable for sea / air freight.

**Components Included in Kit**

**Microbiological Test Kit:**

- 1 x Test kit carry case with integrated work surface
- 1 x Filtration assembly with stainless steel collection body, polyurethane funnel and locking collar, bronze disc, supplied with vacuum pump and sampling cup with stainless steel cable
- 1 x Incubator unit with dual 37°C and 44°C temperature switch, supplied with 20 x aluminium petri dishes with carrier
- 1 x Battery with battery charger, 110/240V AC input, 12V DC output, with travel adapters and cables and 12V cigarette lighter cable
- 5 x Sampling accessories kit consisting of 1 x pad dispenser tool, 5 x media measuring tubes with cap and spoon, 5 x pasteur pipettes, 1 x dilution tube, 1 x beaker, 250 ml, 1 x hand lens, 1 x tweezers/forceps, and 1 x permanent marker
- 1 x Turbidity tube, 2 part
- Colour comparator test kit, with (x3) cuvettes and (x2) chlorine
- 1 x colour comparator wheel for chlorine, (high range 0 - 5 mg/l and low range 0 - 1 mg/l)
- 1 x Pocket sensor, pH with pH buffer fluid

**Consumables Kit for 200 Tests:**

- 2 x Tubes of Absorbent Pads – Gelman Tube of 100 pce
- 1 x 0.45 µm Filter, Membrane - for Water Testing, Box of 200 pce
- 1 x Broth - Lauryl Sulphate, Tub of 38g
- 1 x Rapid test tablets, DPD1, Box of 200 pce
- 1 x Rapid test tablets, DPD3, Box of 200 pce

**Additional Notes / Resources**

- A supply of methanol is an essential requirement for sterilization of the membrane filtration unit. Due to its flammable nature it cannot be shipped with the kit and should be procured locally. Note that alternative substances (alcohol or other spirits) are unsuitable and only pure methanol should be used.
- Note that a number of additional items are required in order to start testing including sterilisation equipment (pressure cooker or similar portable steriliser) and distilled (de-ionised) water. It is also recommended that a room (or area) is set up as a laboratory with fridge (to store consumables) and cooking area (or gas burner) for sterilisation.

Note: last updated, April 2020

Item Application Sample



General Information and Description

Dry powdered media that can be used to simultaneously detect or quantify both total coliforms and Escherichia coli, with accurate results available in 24 hours. The test is rapid to perform taking less than 1 minute. When total coliforms are present the sample turns yellow. When E. coli is present the sample also fluoresces. The media is sufficiently accurate to detect a single viable coliform or E. coli per 100ml sample.

Technical Specifications

**Media:**  
Reagent used for the simultaneous detection and confirmation of total coliforms and E. coli in water. Reagent is presented as individual "snap packs", suitable for testing a 100ml sample of drinking water, packaged in a box of 200.

**120ml Sterile Sampling Bottles:**  
High clarity and non-fluorescing 120ml type 6 recyclable polystyrene sealed sterile vessels for coliform sampling and testing. 100 mL line around entire perimeter to +/- 2.5% accuracy. Bottles pre-sealed with sodium thiosulfate tablet for neutralizing any chlorine in the water sample up to 10 mg/l. Equipped with tamper-evident shrink wrapped seal to protects the entire perimeter from possible contamination

**UV Lamp:**  
Battery powered (4 x AA batteries) 365-nm ultraviolet lamp equipped with a 6-watt bulb for water quality testing purposes.

Components Included in Kit

**Testing Kit:**  
1 x Total coliforms and E. coli reagent suitable for testing a 100ml sample of drinking water, 24 hour incubation, box of 200  
200 x Sterile water sample bottles, 120ml, with tamper proof seal, suitable for testing of drinking water samples, equipped with sodium thiosulfate tablets to neutralize chlorine.  
1 x Battery powered (4 x AA batteries) 365-nm UV lamp equipped with a 6-watt bulb for water quality testing purposes.

Weight, Volume and Packaging

**Gross weight:** 15 kg      **Volume:** 0.04 m<sup>3</sup>  
**Dimensions:** 41 x 24 x 34 cm  
**Packaging:** All items packed in a sturdy cardboard carton suitable for sea / air freight with sufficient packing protection (packing peanuts/ bubble wrap).

Additional Notes / Resources

- Use of testing media requires procurement of a medium sized incubator which allows the temperature to be carefully controlled to 35°C +/- 0.5°C for 24 hours.
- A single sample is only capable of providing a presence/ absence indication of the presence of total coliforms or E.coli in a water sample. Positive samples should be followed up with quantitative water quality sample using either a membrane or a MPN (Most Probable Number) technique.

### HOW TO USE

Presence/Absence Test Procedure



**These test reactions should be seen in ColiAlert:**

		
<b>COLORLESS</b> Negative for total coliforms and E. coli	<b>YELLOW</b> Positive for total coliforms	<b>FLUORESCENT</b> Positive for E. coli

For more information, please call

Note: last updated, April 2020



**Item Application Sample**



**General Information and Description**

Simple bacteriological field testing kit for indicating the presence (or absence) of pathogens in drinking water using a 20ml sample. Media will react on presence of Hydrogen Sulfide Producing Bacteria's (H2S) which are associated with the presence of fecal contamination. The kit comprises a small bottle of bleach disinfecting solution, five 20ml glass vials, and a large bag of 100 powder sachets. The dry powder is completely soluble in water and a dark amber colour solution is formed on the addition of water. The solution will change colour to black in the presence of H2S producing organisms. No incubator is needed provided the sample is kept between 25°C and 44°C for 24-48 hours. No refrigeration is required for the media. The kit could be used in routine testing of water quality as well as during epidemics of water borne diseases. The kit is also useful for educational and motivational campaigns to promote water sanitation and hygiene in outreach and dissemination programs.

**Technical Specifications**

**Media:**

Dry homogenous bacteriological grade powder media used for indicating the presence of hydrogen sulphide producing bacteria in drinking water packed in 20ml sample pillows. Minimum shelf life of two years

**Glass Sampling Bottles:**

High clarity and non-fluorescing 25ml glass vessels for water sampling. 20 mL line around entire perimeter to +/- 2.5% accuracy.

**Components Included in Kit**

**Field Testing Kit:**

- 1 x Bag of medium pillows 20ml sample (100 pcs)
- 5 x Glass sample cells 20ml, with cap
- 1 x Bottle of 6% bleach solution 59ml
- 1 x Durable plastic carrying case
- 1 x Instructions sheet

**Weight, Volume and Packaging**

- Gross weight:** 500g **Volume:** 0.02 m<sup>3</sup>
- Dimensions:** 20 x 8 x 12 cm
- Packaging:** Packed in a sturdy cardboard carton suitable for sea / air freight with sufficient packing protection (packing peanuts/ bubble wrap) for glass components.

**Additional Notes / Resources**

- In groundwater, there is a possibility of sulphides being present and H2S tests may give false positive results of H2S rather than the faecal contamination. Such misclassification of drinking water (false positive rather than false negative) errs on the side of safety.
- H2S is well-suited for monitoring drinking water systems in developing tropical countries where the ambient temperature ranges between 25°C and 44°C. In cold climatic regions (where ambient temperature is below 25°C) the kit should be used with an incubator.
- This kit can be used to perform both presence/absence and (Most Probable Number) MPN tests. If a positive sample is found during a presence/absence test, the five 20ml glass vials should be used in conjunction to perform the quantitative MPN analysis.

**Conducting the P-A Test with PathoScreen Medium**

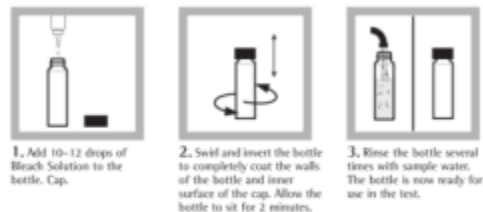

*Note: Wash hands thoroughly with soap and water to minimize contamination of sample*

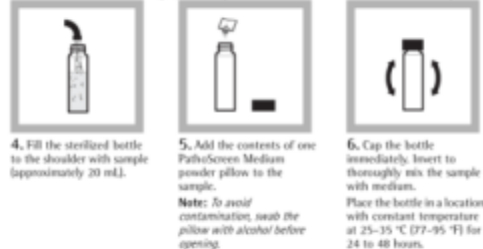

**7. Evaluate the reaction after 24 hours (Table 1). If temperatures have varied significantly, continue to incubate negative samples for an additional 24 hours.**

**Table 1 Interpreting Results**

Hydrogen Sulfide-Producing Bacteria			
Test Results	Positive	Negative	Follow-up
Color changes from yellow to black	X		---
Black precipitate forms	X		---
No color change		X	Incubate additional 12 to 24 hours and reevaluate. If there is no color change, record as negative.

Note: last updated, April 2020

**Item Application Sample**



**General Information and Description**

Test kit to measure the concentration of different chemical parameters in drinking water at the concentration ranges specified by WHO guidelines. The kit has easy to use colour comparator disks and other simple tests that can be carried out after familiarisation and simple training. It is packed in a robust carry case and includes consumables for 50 tests for each parameter. Note that individual colour comparator disks and reagents may be ordered separately instead of the complete set.

**Technical Specifications**

**Colour Comparator Kit:**

Robust, simple to use, compact, potable, visual colour comparator kit with a wide range of chemical parameter options. High quality non-scratch, fade-free, colour disks with definite results (no colour interpretation required). Each kit contains sampling cuvettes, stirring rods, and reagents for 50 tests. Chemical parameters included in the kit and their test ranges include:

- Aluminium: 0-0.5mg/l
- Fluoride: 0-1.5 mg/l
- Iron: 0-10mg/l
- Manganese: 0-0.03mg/l
- Nitrate: 0-15mg/l
- Nitrite: 0-0.4mg/l
- Sulphide: 0-0.5mg/l
- Zinc: 0-4.0mg/l
- Chloride: 0-1000mg/l

Note that Arsenic is not included in the kit and should be ordered separately.

**Additional Notes / Resources**

- Chemical parameters should be tested when they are known to be a problem in the area. For example red staining may indicate iron in the water. Black deposits in the water may indicate manganese. Mottling of teeth in the local population may indicate fluoride. Nitrates and nitrites should be tested when there is a possibility the water supply may be contaminated by septic tanks, latrines, or farming activities. Chlorides should be analysed in arid areas with salt problems. Aluminium should be analysed where water is treated using aluminium sulphate. Zinc should be analysed where rainwater is collected from galvanized roof panels.
- An electronic photometer is an alternative to the individual coloured discs and comparator. The method of preparation of the sample is similar, but the resulting solution is read electronically. A wide range of chemical parameters can be tested with the photometer by buying the appropriate reagents.

[Water Quality Analysis in Emergency Situations – Oxfam \(3.2 MB\)](#)

**Components Included in Kit**

**Chemical Parameter Testing Kit:**

- 1 x Comparator unit
- 4 x Square test tubes, 10ml - for Comparator
- 2 x Dilution tubes
- 1 x Sample tube, cone bottom
- 1 x Syringe, 1ml
- 1 x Cleaning brush - for test tubes
- 10 x Mixing paddles (supplied loose or in tablet boxes)
- 1 x De-ionisation pack
- 1 x Dechlor tablets (x50), EDTA tablets (x50)
- 1 x Aluminium: Comparator kit, range: 0-0.5mg/l
- 1 x Fluoride: Comparator Disc kit, range 0-1.5 mg/l
- 1 x Iron: Comparator Disc kit, range: 0-10mg/l
- 1 x Manganese: Comparator Disc kit, range 0-0.03mg/l
- 1 x Nitrate: Comparator Disc kit, range: 0-15mg/l
- 1 x Nitrite: Comparator Disc kit, range: 0-0.4mg/l
- 1 x Sulphide: Comparator Disc kit, range: 0-0.5mg/l
- 1 x Zinc: Comparator Disc kit, range: 0-4.0mg/l
- 1 x Chloride: Comparator Disc kit, range: 0-1000mg/l
- 1 x Manganese No.1 (x50) Manganese No.2 (x50) test tablets
- 1 x Aluminium No.1 (x50), Aluminium No.2 (x50) test tablets
- 1 x Fluoride No.1 (x100) test tablets
- 2 x Fluoride No.2 (x50) test tablets
- 1 x Iron MR No.1 (x50), Iron MR No.2 (x50) test tablets
- 1 x Nitrate (x50) test tablets
- 1 x Nitrate powder (x50)
- 1 x Nitricol (x50) test tablets
- 1 x Sulphide No.1 (x50) test tablets
- 1 x Sulphide No.2 (x50) test tablets
- 1 x Zinc (x50) test tablets
- 1 x Chloride (x100) test tablets

**Weight, Volume and Packaging**

- Gross weight: 3.2 kg      Volume: 0.04 m<sup>3</sup>
- Dimensions: 39 x 34 x 34 cm
- Packaging: Packed in a sturdy tri-wall cardboard carton suitable for sea / air freight with sufficient packing protection (packing peanuts/ bubble wrap) especially for fragile or glass components.

Note: last updated, April 2020



Item Application Sample

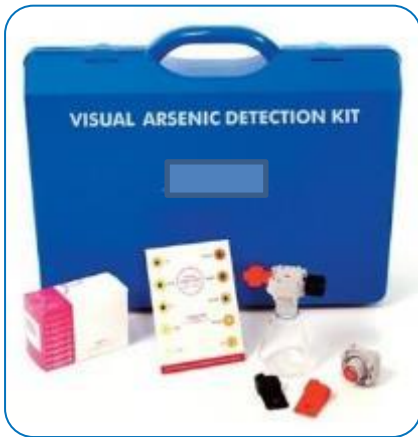

General Information and Description

Portable arsenic detection kit which allows for semi-quantitative visual analysis of arsenic in drinking water in the field. The kit is used to detect in the field the presence of arsenic in water in concentrations ranging from less than 10 ppb up to 500 ppb. Each test takes approximately 20 minutes after which the results can be determined visually using a colour comparison chart. The kit has sufficient tablets, powder sachets and filters to conduct 200 tests.

Technical Specifications

Visual Arsenic Detection Kit:

A portable visual arsenic detection kit which allows for semi-quantitative visual analysis of arsenic in drinking water for the range from less than 10 µg / litre (ppb) up to 500 µg / litre (ppb). The kit includes a reaction vessel which features a unique tri-filter cap which removes excess arsine gas as well as any hydrogen sulphide which may also be given off as a by-product of the reaction. The kit has sufficient tablets, powder sachets and filters to conduct 200 tests. The complete kit is housed in a robust plastic carrying case with handle. Measuring scale: <10, 20-40, 50, 60-80, 100, 100-200, 200-300, 300-400, 400-500, 500 µg / litre (ppb).

Components Included in Kit

Visual Arsenic Detection Kit:

- 1 x Graduated reaction flask with tri-filter cap
- 1 x Graduated dilution tube
- 4 x Hydrogen sulphide removal filters
- 4 x Black filter slides (detection)
- 4 x Red filter slides (removal)
- 1 x Tub of filters papers (arsenic test labelled "Black") x 200 pce
- 1 x Tub of filters papers (removal labelled "Red") x 200 pce
- 1 x Bag of powder sachets labelled "A1" x 200 pce
- 1 x Tub of tablets labelled "A2" x 200 pce
- 1 x Colour comparison chart
- 1 x Cleaning brush
- 1 x Waste disposal bag
- 1 x Pair of forceps
- 1 x Pair of surgical gloves

Weight, Volume and Packaging

- Gross weight: 4 kg
- Volume: 0.02 m<sup>3</sup>
- Dimensions: 47 x 36 x 11 cm
- Packaging: Packed in a sturdy cardboard carton suitable for sea / air freight.

Note that the reagents in the arsenic detection kit are classed as hazardous material – a transport certificate is required!

Additional Notes / Resources

- The WHO guideline value for arsenic in drinking water is 0.01 mg/l. However, in some areas where arsenic is more prevalent and choice of water sources is limited national governments may use the older WHO guideline of 0.05 mg/l.
- Note that this kit will only allow the user to see whether 0.01 mg/l is present (giving a yes/no against the WHO guideline). A second more expensive digital arsenic test kit is also available which can measure accurately the range 0.002 - 0.1 mg/l. In some areas this may be more suitable.

VisuPAS Operation Manual

Operation Equipment Key



Stage 1: Loading bung device

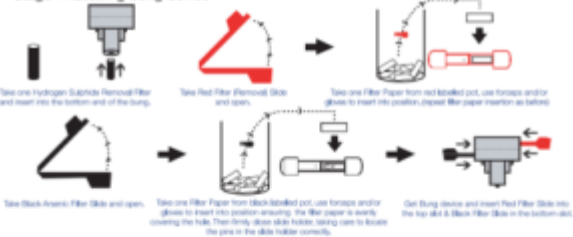

Stage 2: Sample Preparation

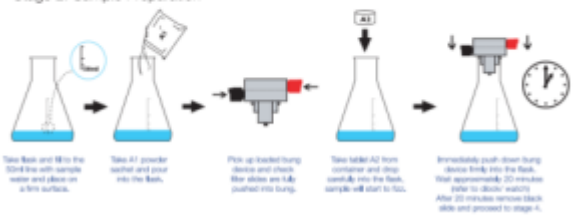

Note: last updated, April 2020





**Item Application Sample**



**General Information and Description**

Hand held pocket sized electrical conductivity meter having a range of 0-20 mS/cm and resolution 0.01ms/cm.

**Technical Specifications**

**Pocket Conductivity Meter:**

Hand-held durable waterproof pocket sized electrical conductivity meter with automatic temperature compensation and temperature displayed on screen. Waterproof to IP67 to protect the instrument in all environments. Automatic standard recognition of buffer solutions for straightforward calibration. Measuring range of 0-20 mS/cm and resolution 0.01ms/cm to +/-1% accuracy. Temperature range 0°C - 50°C. Powered by 4 x A76/LR44 button cell batteries.

**Components Included in Kit**

**Pocket Conductivity Meter:**

- 1 x Pocket conductivity meter 0-20 mS/cm
- 1 x Calibration solution bottle 50ml
- 1 x Spare batteries (pack of 4 x A76/LR44 button cell batteries)

**Weight, Volume and Packaging**

- Gross weight:** 150 g                      **Volume:** 0.005 m<sup>3</sup>
- Dimensions:** 6 x 5 x 18 cm
- Packaging:** Packed in a sturdy cardboard carton suitable for sea / air freight.

**Additional Notes / Resources**

- The conductivity meter is used primarily to calculate the concentration inorganic salts and small amounts of organic matter present in solution in water total (total dissolved solids TDS) which is calculated based on the established factor that TDS = conductivity  $\times$  0.67 at 25°C. The principal constituents of total dissolved solids are usually calcium, magnesium, sodium, and potassium cations and carbonate, hydrogencarbonate, chloride, sulfate, and nitrate anions.
- Water becomes increasingly unpalatable at levels of TDS greater than 600 mg/l and should not exceed 1,000 mg/l.

Note: last updated, April 2020

Item Application Sample



General Information and Description

Portable, durable, digital balance for precision measurement of water treatment chemicals (chlorine, aluminium sulphate etc.).

Technical Specifications

Portable Digital Balance:

Portable, durable, digital balance for measurement of water treatment chemicals (chlorine, aluminium sulphate etc.) with large back-lit LCD, x10 overload protection, fast stabilization time, ABS housing and 170mm stainless steel pan, transportation lock and calibration lock, low battery indicator, auto shut-off, auto tare, six units of measurement (g, kg, newton, lb, ounce), weigh below hook, carry case, AC adapter (included) or 4 AA batteries (not included) and simple 4 button operation.

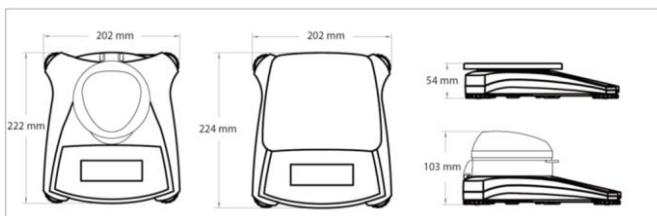

Components Included in Kit

Portable Digital Balance:

- 1 x 220g x 0.1g portable digital balance
- 1 x AC adapter cable
- 1 x ABS carrying and storage case

Weight, Volume and Packaging

- Gross weight: 1.6 kg                      Volume: 0.005 m<sup>3</sup>
- Dimensions: 20 x 22 x 5 cm
- Packaging: Packed in a sturdy cardboard carton suitable for sea / air freight.

Additional Notes / Resources

- Similar potable precision balance may be procured locally if available.

Note: last updated, April 2020

## **SECTION SIX**

# **LATRINES SANITATION AND SOLID WASTE**



**Item Application Sample**



**General Information and Description**

Pallet of 35 self-supporting plastic latrine slabs for first phase emergency use. Ideal for family and communal latrines (health centres, feeding centres, schools). Note that there is an additional insert available to convert the slab into a pour-flush latrine (needs to be ordered separately).

**Technical Specifications**

**Emergency Latrine Slab:**

UV resistant, mould and mildew resistant, low density polyethylene (LLDPE) latrine squatting slab 1.2m long x 0.8m wide x 55mm thick, neutral colour, with thermal stability -30°/+70°C. Design is self-supporting able to support a static load of 150kg across spans of up to 0.9m wide. Upper surface equipped with raised foot rests with anti-slip grooves and HDPE (UV protected) hinged close fitting hole cover with foot operated opening mechanism. Lower surface equipped with five M6 x 15mm brass moulded inserts for bolting on a pan and trap. Holes are provided on the extreme four corners of the squatting plate through which four 8 mm x 275 mm steel pegs are inserted. The pegs are included with each slab installed on the underside of the plate.

**Components Included in Kit**

**Emergency Latrine Slab Kit:**

35 x Self-supporting plastic latrine slabs

**Weight, Volume and Packaging**

**Gross weight:** 394 kg                      **Volume:** 2 m<sup>3</sup>  
**Dimensions:** 120 x 80 x 210 cm  
**Packaging:** 35 units stacked on a single euro pallet and secured with PVC bands and pallet wrap for sea / air freight.

**Additional Notes / Resources**

- One slab should be allowed for 50 people in the first phase of the emergency but the number should gradually reduce to 20 people per latrine as quickly as possible.
- This slab can be used as a direct drop self-supporting slab or a pour-flush slab. As a direct drop slab it may be used on trenches or pits up to 0.9m wide so that there is at least 10cm of the slab firmly on the ground. The slab needs no supporting members under it. The pit edge must be firm and stable before installing the slab. Good practice is to always put a lintel of concrete, bricks or blocks around the top of the pit to receive/hold the slab. The slab may also be incorporated into raised designs.

[Excreta Disposal in Emergencies – WEDC \(PDF 14.2 MB\)](#)

Note: last updated, April 2020



Item Application Sample



General Information and Description

Kit to convert plastic self-supporting latrine slabs into hygienic pour-flush toilets for first phase emergencies where communities use water for flushing and anal cleansing.

Technical Specifications

**Plastic Pour Flush Latrine Pan:**

2mm thick plastic polypropylene copolymer (PPCP) pour flush toilet pan with a slope of 35 degrees (for easy flush and reduced water requirement) and exit pipe size of 81mm (OD). The pan is scratch, hydrochloric acid and uric acid resistant 470mm long x 250mm wide x 345mm high with five holes for bolting onto the underside of a self-supporting latrine slab. Pan is securely attached to a 2.5mm thick plastic PPCP toilet P-trap with a 20 mm water seal to minimise odours, 81.7mm (ID) inlet pipe and 104.5mm (OD) exit pipe. The exit pipe has a slope of 10 degrees for easy flushing and reduced usage of water. Kit is supplied with five brass M6 x 15 bolts and adhesive for ensuring a hygienic seal.

Components Included in Kit

**Emergency Latrine Slab Kit:**

35 x Pour flush toilet pans, 2mm thick, PPCP, 470mm x 250mm  
 35 x Toilet p-traps, 2.5mm thick, PPCP  
 35 x Screws, M6 x 15mm, brass, with brass plain washers (x5)  
 35 x Adhesive 0.5g

Weight, Volume and Packaging

**Gross weight:** 32 kg                      **Volume:** 0.39 m<sup>3</sup>  
**Dimensions:** 120 x 80 x 41 cm  
**Packaging:** 35 units stacked on a single euro pallet and secured with PVC bands and pallet wrap for sea / air freight.

Additional Notes / Resources

- The pour-flush kit is fixed to the underside of a latrine slab using the brass screws provided. The P-trap is joined to the pan using adhesive. The P-trap is then connected by pipe to a septic tank, reception/ holding tank, a stabilisation pond or existing sewer. Alternatively it can exit directly into a tank below the slab (to work as a 'U' trap). It is good practice for the drainpipe to have a slope of at least 2% to the tanks to facilitate easy flow and minimise silt and blockages.
- When installing this system, ensure there is enough water to flush the toilet and provision should also be made for collection of water near the toilet. It is good practice to allow at least 4 litres per person per day for pour-flushing and anal washing.

Note: last updated, April 2020

Item Application Sample



General Information and Description

High quality and robust hand tools for accelerating family latrine construction activities. Kit can also be useful for defecation zones, clean up campaigns or for preparing all types of groundworks including: latrine, pit, trench digging, ground preparation for foundations and road repairs.

Components Included in Kit

Family Latrine Digging Kit:

- 10 x Spades with square mouth straight wooden shaft with handle.
- 10 x Shovel with round mouth and straight wooden shaft with handle.
- 10 x Pickaxe 7lb head, chisel and point with hard wood shaft
- 6 x Bucket, 16 litre, galvanised steel
- 6 x Rake, 12-tooth head, blade width 280mm, with wooden handles and screws for fixing
- 5 x Miners' bar, chisel and point, 3cm dia. x 1.5m
- 5 x Bolster, length 225mm, blade width 75mm
- 5 x Lump hammer, 4lb
- 1 x Measuring tape, length 30m, width 13mm
- 2 x Roll of rope, 8mm, polypropylene, length 30m
- 1 x Roll of site marking tape, red/white, 500m

Weight, Volume and Packaging

**Gross weight:** 152 kg                      **Volume:** 0.56 m<sup>3</sup>  
**Dimensions:** 148 x 60 x 63 cm  
**Packaging:** Tools to be packed in a sturdy timber crate suitable for sea / air freight.

Additional Notes / Resources

- If it is clear that the time-frame of the humanitarian situation will be longer than six months, the best guarantee that people will safely defecate in a toilet and that toilets are kept clean and functional is to encourage the construction of shared or individual household toilets as quickly as possible.
- The immediate construction of one toilet shared between four families avoids the complications and costs that typically arise with communal facilities as families take responsibility for cleaning and maintenance themselves.
- UNHCR and WASH actors should ensure that the refugee population have access to tools and technical support to construct, maintain and clean their own toilets from the outset of the refugee emergency. UNHCR and WASH actors may plan to provide one set of tools (spade, shovel, pick, bucket, hammer, chisel) that is shared between every 10 families.
- Marking tape and polypropylene rope are included in the kit in case the contents are used to prepare defecation areas.

Note: last updated, April 2020



Item Application Sample

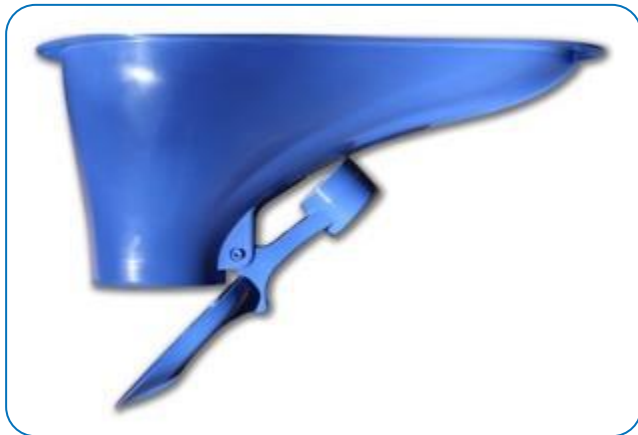

General Information and Description

Inexpensive, innovative, durable, sanitary, easy to clean, plastic, low-volume pour-flush toilet pan designed for cultures where pour-flush squat type toilets are the norm. The weighted trap design forms a water seal at the bottom of the pan reducing odours and sealing the vault contents from flies and other vectors. The volume of water needed to flush is less than half a litre.

Technical Specifications

Pour flush toilet consisting of two plastic (polypropylene resin) parts: a pour flush pan with smooth surface finish; and a trap door mechanism with integrated counterweight cup. Design should be durable enough to withstand more than 500,000 flush cycles.

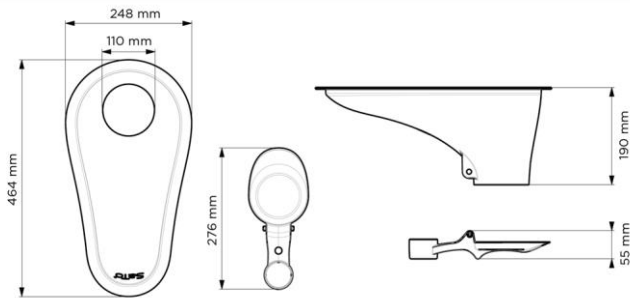

Weight, Volume and Packaging

Gross weight: 32 kg                      Volume: 0.39 m<sup>3</sup>  
 Dimensions: 100 x 80 x 60 cm  
 Packaging: 35 units stacked and secured in a durable tri-wall carton suitable for sea / air freight.

Additional Notes / Resources

- The plastic pour-flush pan cannot be used immediately and needs to be cast into a lightly reinforced concrete slab before installation. Time and resources should be planned for this.
- A small amount of concrete (150g) from the slab is required to fill the counterweight cup. Care should be taken not to overfill the counterweight cup as the balance is critical for ensuring a flush with minimal water. Make sure the cup is filled to the fill line and not to the top of the cup.

Note: last updated, April 2020

Item Application Sample



General Information and Description

Kit containing the basic tools required for a solid waste clean-up operation for up to 50 workers. It can also be used for ground clearance and road surface repairs or where rubble and debris needs to be cleared. Note that the kit does not include worker personal protective equipment which should be ordered separately.

Components Included in Kit

Solid Waste Clean Up Kit:

- 50 x Rake, 12 tooth head, with wooden handle
- 50 x Spade, trenching, round mouth blade - size 12"x10", with wooden handle
- 12 x Pickaxe, chisel and point, with wooden handle
- 25 x Wheelbarrow, Heavy duty, 90-150L/120kg capacity
- 25 x 1m<sup>3</sup> heavy duty, woven polypropylene bags sacks used for collection and transport of solid waste material, open top with 4 lifting loops.

Weight, Volume and Packaging

	Gross weight:	Volume:	Dimensions:
Crate 1	330 kg	1.12 m <sup>3</sup>	122 x 85 x 152 cm
Crate 2	230 kg	1.02 m <sup>3</sup>	150 x 133 x 100 cm
Packaging:	Tools to be packed in a sturdy timber crate suitable for sea / air freight.		

Additional Notes / Resources

- Tools may be purchased locally if available. Ensure that tools are durable and strong enough for heavy-duty jobs. The wheelbarrow should have a pneumatic tyre. Where possible, buy rakes, spades, and pickaxes with fixed heads on shafts.
- Protective safety wear is important for workers likely to be handling contaminated materials and sharp debris.

Note: last updated, April 2020

Item Application Sample



General Information and Description

Kit containing the basic personal protective equipment required for a solid waste clean-up operation for up to 50 workers. It can also be used for ground clearance and road surface repairs or where rubble and debris needs to be cleared. Note that the kit does not include solid waste collection equipment and tools which should be ordered separately.

Components Included in Kit

Solid Waste Worker Protection Kit:

- 50 x Pairs of wellington type safety boots (mixture of different sizes from EU shoe size 38 to 47), high grade blend of PVC and nitrile rubber, steel toe caps with 2000 joule rating, mild steel mid sole for penetration resistance, easy clean surface.
- 50 x High visibility polyester vests for work teams (mixture of different sizes M / L / XL), bright orange or yellow with reflective tape.
- 100 x Pairs of heavy duty, 30cm length, waterproof (full immersion), puncture proof durable rubber gloves (mixture of different sizes M / L / XL), with super grip surface.
- 800 Disposable face mask, flexible adjustment string, light weight, cone type, made from 100% polyester
- 50 Polyester coveralls in small 38", medium 42", large 46" and extra-large 50", royal blue, stud front fastenings, easy wash.

Weight, Volume and Packaging

- Gross weight: 192 kg                      Volume: 1.42 m<sup>3</sup>
- Dimensions: 148 x 94 x 99 cm
- Packaging: Tools to be packed in a sturdy timber crate suitable for sea / air freight.

Additional Notes / Resources

- Protective safety wear is essential for all workers especially if it is likely they may be handling contaminated or sharp materials.
- Personal protective equipment may be purchased locally if available. Ensure that clothing (in particular boots and gloves) are durable and strong enough for heavy-duty jobs especially if there is a risk of puncture (e.g. waste collection).

Note: last updated, April 2020

# **SECTION SEVEN**

## **HYGIENE PROMOTION**





Item Application Sample



General Information and Description

General purpose, fresh fragranced, long durability, mild soap in 125g bars suitable for both baby and adult personal use in addition to washing and laundry. Soap may also be procured for use in health or education programming etc.

Technical Specifications

**Multi-Purpose Soap Bars:**

General purpose, fresh fragranced, long durability, mild soap in 125g bars suitable for both baby and adult personal use in addition to washing and laundry. Made using animal or vegetable fat, the bar contains a minimum of 65% fatty acid and 1% glycerine. pH value should be 9-11 and soap should not contain more than 0.2% NaOH (Sodium Hydroxide) and 0.5 NaCl (Sodium Chloride). The moisture content should be no more than 20% ensuring the bar will not wear too quickly. Soap should not contain fat from pigs.

Weight, Volume and Packaging

**Gross weight:** 284 kg                      **Volume:** 0.59 m<sup>3</sup>  
**Dimensions:** 120 x 80 x 53 cm  
**Packaging:** 2,100 bars packed in boxes of 100 units stacked on a single euro pallet and secured with PVC bands and pallet wrap for sea / air freight.

Additional Notes / Resources

- Sphere minimum standards are set at 250g per person per month for washing and 200g per person per month for laundry. Some cultures may require more soap than this (or powdered soap for laundry purposes) and professional judgement and programme experience should be used to estimate the right types and quantity of soap required. Ensure that the colour and odour will also be acceptable to beneficiaries.
- If soap is purchased locally ensure that the soap is of good quality. The NaOH content can be used as an indication of the level of purity. Generally soaps with high content of NaOH may irritate the skin. Check that the soap is mild on the skin before buying. Also check that the colour and odour will also be acceptable to beneficiaries. Soap containing pork fat may be culturally unacceptable in some countries, so check for type of fat used for soap making.
- More information can be found in the UNHCR Core Relief Items Catalogue Item 01511.

Note: last updated, April 2020





Item Application Sample



General Information and Description

Dark coloured, absorbent, brushed 100% cotton flannel material for sanitary purposes in squares of 1 m x 1.5 m.

Technical Specifications

**Multi-Purpose Absorbent Cloth:**

Cloth made of 100% brushed absorbent cotton, both sides raised, with approximate size of 1 m x 1.5 m and fabric weight of 170-180g/m<sup>2</sup>. Warp: minimum 21 threads per cm, Weft: minimum 18.5 threads per cm. Yarn: 30 tex in warp and 50 tex in weft +/- 2%. pH: 6 – 8.5. Colour: natural, dark brown or grey.

Weight, Volume and Packaging

**Gross weight:** 158 kg      **Volume:** 0.74 m<sup>3</sup>  
**Dimensions:** 120 x 110 x 56 cm  
**Packaging:** Total of 200 pieces. Each piece of cloth to be folded and placed in a 30cm x 40cm plastic bag. Each 100 bags should be wrapped into a bale. Total 2 bales.

Additional Notes / Resources

- The soft-brushed cotton is provided to meet the sanitary needs of women and girls but can equally be used for other purposes such as bathing towels or infant nappies.
- The materials are intended to be distributed in the early phases of an emergency response however when the needs of women and girls are better understood, more appropriate 'sanitary materials' can be sourced depending on cultural context.
- In some contexts packaged sanitary towels may be more appropriate according to context.
- If sanitary cloth is to be purchased locally ensure that the cotton is soft, can easily absorb liquid, is of an appropriate colour, and meets local cultural preferences.
- More information can be found in the UNHCR Core Relief Items Catalogue – Item 06137.

Note: last updated, April 2020

**Item Application Sample**



**General Information and Description**

Simple and robust child's plastic potty with handle; ideal for disposing of children's (under 3 years old) faeces.

**Technical Specifications**

**Child's Potty:**  
Simple and robust child's potty with handle made from durable plastic, stable on floor, diameter 20cm approx.

**Weight, Volume and Packaging**

**Gross weight:** 50 kg      **Volume:** 0.74 m<sup>3</sup>  
**Dimensions:** 120 x 110 x 56 cm  
**Packaging:** 72 units stacked on a single euro pallet and secured with PVC bands and pallet wrap for sea / air freight.

**Additional Notes / Resources**

- Distribute 1 per family with children under 3 years old.
- Check that both use of potties and the colours available are culturally acceptable before ordering.
- Depending on availability it may be possible to procure potties locally.

Note: last updated, April 2020



Item Application Sample



General Information and Description

Lightweight, portable, hand-held 20 watt megaphone used in hygiene promotion campaigns, especially during disease outbreak.

Technical Specifications

**Hand-held Megaphone:**

Lightweight, portable, hand-held 20 watt megaphone used in hygiene promotion campaigns, especially during disease outbreak. Minimum 20 watt high quality speaker with clear sound projection up to 500m. Body constructed from durable ABS plastic. Rechargeable battery with charger unit and 220V AC cables. Battery to provide at least 8 hour continuous use running capacity. Durable shoulder strap of at least 1.2m length.

Components Included in Kit

**Hand-held Megaphone:**

1 x Megaphone, portable, 20 watts with carrying strap  
1 x Rechargeable battery  
1 x Battery recharging unit

Weight, Volume and Packaging

Gross weight: 4 kg                      Volume: 0.03 m<sup>3</sup>  
Dimensions: 36 x 25 x 25 cm  
Packaging: Single packed in a durable carton suitable for sea / air freight.

Additional Notes / Resources

- If purchased locally be sure to check the sound quality and range of the speaker unit in addition to the battery life and general build quality.

Note: last updated, April 2020



**Item Application Sample**



**General Information and Description**

Laminator for all sizes up to A3 (296 x 420mm) used for making hygiene promotion materials (posters, games etc.) durable and water resistant. Laminator unit kit also contains 100 x A3 pouches, 100 x A4 pouches and 100 x ID card pouches.

**Technical Specifications**

**Laminator Kit:**

Electric laminating unit for all sizes up to A3 (296 x 420mm). Unit is able to laminate all standard pouches of variable thickness, composition or melting point up to 2 x 250 (500) microns. Variable temperature control. Fast warm up time (less than 4 minutes). 2 year defects guarantee.

**Components Included in Kit**

**Laminator Kit:**

- 1 x A3 Laminator unit, multi-size, adjustable, 240V AC
- 1 x Lamination pouches, A3 size, (pack of x100)
- 1 x Lamination pouches, A4 size, (pack of x100)
- 1 x Lamination pouches, ID Card size, (pack of x100)

**Weight, Volume and Packaging**

**Gross weight:** 12 kg                      **Volume:** 0.02 m<sup>3</sup>  
**Dimensions:** 57 x 20 x 20 cm  
**Packaging:** Packed in a durable carton suitable for sea / air freight.

**Additional Notes / Resources**

- A laminating unit is a useful item for developing hygiene promotion materials. Pictures for hygiene promotion discussions can be photocopied, coloured and laminated for use in the communities. Digital photos, flash cards, posters, PRA materials etc. can also be laminated.
- If purchased locally be sure to check the general build quality, availability of pouches, and guarantee.
- The laminating unit can be used additionally to process ID cards for programme and field staff.

Note: last updated, April 2020

### Item Application Sample

#### Equipment



#### Consumables



### General Information and Description

Kit to facilitate cleaning and disinfection of environmental surfaces, and support handwashing in schools during emergency situations (e.g. cholera or COVID-19 – however ideally all refugee schools should have cleaning and handwashing equipment and supplies). Supplies sufficient for 3 months (500 students).

### Components Included in Kit

#### Cleaning and Disinfection Equipment:

- 2 x Stiff floor brush 40cm head.
- 2 x Floor mop (separate equipment for classrooms and toilets).
- 2 x Plastic mop bucket 20 litres, durable, HDPE with durable mop draining fixture.
- 1 x General purpose backpack sprayer (15 litres), HDPE, resistant to a wide number of chemicals including chlorine solutions, pumping lever, trigger handle, anatomical design.

#### Cleaning and Disinfection Supplies:

- 2 x Liquid floor washing detergent soap (20 litres).
- 10 x Cotton cleaning cloths (50cm x 50cm) for wiping surfaces.
- 5 x Liquid bleach (5 litres) 6% for floor disinfection.
- 100 x Garbage bags, black, 60 litres, heavy duty

#### Handwashing Supplies and Equipment

- 5 x Handwashing stations (100 litres), fitted with dispenser tap, HDPE, UV resistant, tripod legs, and soap holder.
- 4 x Liquid handwashing soap (20 litres).

#### Personal Protective Equipment for Teachers and Staff:

- 200 x Disposable face mask, flexible adjustment string, light weight, cone type, made from 100% polyester

#### Personal Protective Equipment for Cleaning Staff:

- 4 x Acrylic full face shields, full 180 degree protection with head mount
- 4 x Pairs of white coloured wellington type boots (mixture of different sizes from EU shoe size 38 to 47), high grade blend of PVC and nitrile rubber, easy clean surface.
- 4 x Polypropylene coveralls in small 38", medium 42", large 46" and extra-large 50", disposable.
- 10 x Pairs of heavy duty, 30cm length, waterproof (full immersion), puncture proof nitrile rubber gloves (mixture of different sizes M / L / XL), with super grip surface.
- 100 x Disposable face mask, flexible adjustment string, light weight, cone type, made from 100% polyester

### Additional Notes / Resources

- All school cleaning, disinfection and handwashing equipment should be purchased locally (in country) if available. Ensure that equipment (in particular buckets, brushes, mops, sprayers, handwashing stations) are durable and strong enough to withstand intensive use. Types and quantities of equipment and consumables are provided as a guide and should be adapted to local context - for example if pre-fabricated handwashing stations are not available then they may be substituted for a 100 litre HDPE drum with lid, rubber washers, tap and raised support.
- Supplies may be distributed to refugee schools as a one-off intervention with repeated top-ups of consumables (masks, bleach, detergent, handwashing soap, garbage bags) every three months or as required.
- If liquid soap and liquid soap dispensers are not available, liquid soap may be substituted for powdered laundry soap (added directly to handwashing water) or soap bars. Liquid soap is preferable to avoid theft. All soap should meet the UNHCR specification for refugee body soap (min 65% fatty acid and 1% glycerine; max 0.2% NaOH Sodium Hydroxide; minimum 2 years shelf life etc.).
- Laundry soap powder may also be substituted for liquid floor detergent if it is unavailable.
- Separate mopping equipment should be kept for bathrooms and the rest of the school.
- Liquid bleach should be diluted down to 0.5% for daily disinfection of toilets, bathrooms and showers. If liquid bleach is unavailable, chlorine solutions can be prepared locally from chlorine powders (high test hypochlorite) and water.
- Application of disinfectants to frequently touched environmental surfaces should be via a cloth or wipe which is soaked in the disinfectant. Routine application of disinfectants to surfaces via spraying is not recommended, particularly in indoor spaces where there is an aerosol risk.
- UNHCR is currently recommending a planning figure of at least **one functional handwashing station for every 100 refugee children**. In addition, UNHCR is recommending a planning figure of **50g of powdered soap, 50ml of liquid soap, or 50g of solid soap per student per month** (based on handwashing with 0.5g of soap five times a day).
- More guidance on daily cleaning requirements including preparing disinfection solutions and can be found at the following link: <https://wash.unhcr.org/covid-19-resources/>

### Weight, Volume and Packaging

Gross weight:	210 kg	Volume:	0.52 m <sup>3</sup>
Dimensions:	110 x 38 x 120 cm		
Packaging:	Items packed in a sturdy tri-wall export quality carton suitable for sea / air freight.		

Note: last updated, July 2020

**SECTION EIGHT**

**DISEASE VECTOR CONTROL**



**Item Application Sample**



**General Information and Description**

Portable, general purpose 15 litre, hand operated spray equipment for strong chlorine solutions and insecticides. Used for disinfection activities or the control of disease vectors (flies, mosquitoes, vermin). Suitable for use with solutions or wettable powders. Note that for Malaria indoor residual spraying (IRS) programs (malaria control) it is necessary to order spray equipment with steel tanks that conform to WHO specifications.

**Technical Specifications**

**General Purpose Backpack Sprayer:**

15 litre capacity backpack polyethylene tank made of high density polyethylene (HDPE). Resistant to wide variety of chemicals and atmospheric conditions with ultra-violet resistance. Wide funnel-shaped tank mouth for easy filling. Anatomical designed for greater operator comfort. Fitted with strap, 135cm pressure hose, and robust piston type pump with high output with the minimum number of strokes per minute. Sprayer pump brass or stainless steel. Working pressure from 1–3 bars (15–45psi), left or right hand operation. Safety valve to prevent tank from over pressurizing (max pressure 3 bar).

**Components Included in Kit**

**General Purpose Backpack Sprayer:**

- 1 x Backpack sprayer tank HDPE, 15 litres
- 1 x Pumping lever with plastic covered handle
- 1 x Trigger valve
- 1 x Extension tube, 60cm x 10mm diameter, brass
- 1 x Spare nozzles and accessories
- 1 x Nozzle, plastic, JD-12p

Instruction, operating and maintenance manual shall be included in addition to spare parts lists.

**Weight, Volume and Packaging**

<b>Gross weight:</b>	6 kg	<b>Volume:</b>	0.04 m <sup>3</sup>
<b>Dimensions:</b>	70 x 21 x 34 cm		
<b>Packaging:</b>	Packed in a durable tri-wall export quality carton suitable for sea / air freight.		

**Additional Notes / Resources**

- UNHCR and WASH actors must ensure that all staff involved in disease vector chemical control application programmes have adequate personal protective equipment and safety training for the tasks they are carrying out.

Note: last updated, April 2020

**Item Application Sample**

**General Information and Description**

Robust and high quality, portable spraying equipment approved by WHO for indoor residual spraying (IRS) malaria control programmes. It is recommended for use with solutions or wettable powders.

**Technical Specifications**
**Metal Tank Sprayer for Malaria Programmes:**

Stainless steel 11 litres cylindrical compression sprayer, hand operated, for indoor residual spraying applications. Equipped with a hand operated air pump with two handed handle and locking device separate from the tank lid, pressure relief (safety) valve device, air pressure gauge, shut-off valve to keep the pressure in the tank if the hose and the discharge set removed, hose attached at the top of the tank, trigger valve with locking off device, lance, control flow valve and nozzle. The sprayer shall be equipped with a system for hanging the lance when the sprayer is not in use. The operation pressure of the sprayer shall be 4 bar. The sprayer shall be equipped with flow rate control device to maintain a relatively even discharge rate and a uniform nozzle pressure according to paragraph 2.10.4 in WHO 2010 revised edition of vector control equipment. Sprayer, sprayer's parts and accessories shall be certified to tests stated in in Equipment for Vector Control Specification Guidelines, WHO revised edition 2010.

**Components Included in Kit**
**Metal Tank Sprayer for Malaria Programmes:**

- 1 x Sprayer tank stainless steel, 11 litres
- 1 x Pumping lever
- 1 x Trigger valve
- 1 x Extension tube, 60cm x 10mm diameter, brass
- 1 x Spare nozzles and accessories

Instruction, operating and maintenance manual shall be included in addition to spare parts lists.

**Weight, Volume and Packaging**

**Gross weight:** 6 kg                      **Volume:** 0.03 m<sup>3</sup>

**Dimensions:** 70 x 21 x 21 cm

**Packaging:** Packed in a durable tri-wall export quality carton suitable for sea / air freight.

**Additional Notes / Resources**

- UNHCR and WASH actors must ensure that all staff involved in disease vector chemical control application programmes have adequate personal protective equipment and safety training for the tasks they are carrying out.

Note: last updated, April 2020



**Item Application Sample**



**General Information and Description**

Kit containing the personal protective equipment which must be worn when undertaking vector control activities (insecticide application, indoor residual spraying etc.). Kit may also be used for staff working with water treatment chemicals (e.g. chlorine, aluminium sulphate) or involved with sewage desludging activities, or waste management and disinfection in healthcare facilities.

**Components Included in Kit**

**Vector Control Worker Protection Kit:**

- 10 x Pairs of white coloured wellington type boots (mixture of different sizes from EU shoe size 38 to 47), high grade blend of PVC and nitrile rubber, easy clean surface.
- 10 x Acrylic full face shields, full 180 degree protection with head mount
- 10 x PVC eye goggles (full front and side protection)
- 10 x Heavy duty apron, full length, saranex
- 100 x Pairs of heavy duty, 30cm length, waterproof (full immersion), puncture proof nitrile rubber gloves (mixture of different sizes M / L / XL), with super grip surface.
- 100 x Disposable face mask, flexible adjustment string, light weight, cone type, made from 100% polyester
- 100 x Polypropylene coveralls in small 38", medium 42", large 46" and extra-large 50", disposable.

**Weight, Volume and Packaging**

**Gross weight:** 70 kg                      **Volume:** 0.52 m<sup>3</sup>  
**Dimensions:** 110 x 38 x 120 cm  
**Packaging:** Items packed in a sturdy tri-wall export quality carton suitable for sea / air freight.

**Additional Notes / Resources**

- Protective safety wear is essential for all staff working with vector control chemicals, sewage or water treatment chemicals.
- Personal protective equipment may be purchased locally if available. Ensure that clothing (in particular boots, goggles and gloves) are durable and strong enough.

Note: last updated, April 2020

# **SECTION NINE**

## **WASH DOMESTIC ITEMS**

**Item Application Sample**



**General Information and Description**

10 litre capacity semi-collapsible jerry can made of food grade LDPE for general household storage of drinking water.

**Technical Specifications**

**Capacity:** 10 litres

**Weight:** 190 – 230 g.

**Material:** Manufactured of food grade LDPE should not contain toxic elements according to EN 1186-3-9. The jerry can must stand by itself, even when filled with less than 1/4 of its maximum volume.

**Operating Temperature:** Temperature resistance from -20°C to + 50°C.

**Average thickness:** 0.6 mm and minimum corner thickness 0.5 mm.

**Fitted with:** Built-in carrying handle with minimum 9 cm length and 3 cm height, with no sharp edges and a screwable cap for filling and discharge, linked to the container by polyamide string with diameter of min.1 mm and approximately 120 mm length. The inner diameter of the cap is approx. 35 mm.

**Impact Resistance / Drop Test:** The Semi-Collapsible Jerry Can must be impact resistant on a hard surface when filled with maximum volume of water (10 liters) at 20 °C. The complete drop test consists of 10 consecutive drops from 2,5 m high. The jerry can must be elevated, so that the lowest point is at 2,5 m from the ground. Test result is expressed as a product ranking according to the number of drops passed without damages or leakage. To be accepted, the jerry can must resist to minimum 3 drops.

**Life Span / Shelf Life:** It is expected that the collapsible jerry can will last for six months of use under tropical conditions. The product should have a shelf life of 3 years.

**UNHCR Logo:** Embossed on minimum one side with UNHCR visibility logo, as per UNHCR graphic reference.

**Manufacturer's Marking:** Every unit should include the manufacturer's identification mould, at 5 cm above the bottom with letters not higher than 1.5 cm and on the opposite side of the UNHCR logo or on the side distant from UNHCR logo. The marking should include the manufacturer's name, unique reference batch number and date of manufacturing. No company logo should be included with the manufacturer's marking.

**Weight, Volume and Packaging**

**Gross weight:** 12 kg

**Volume:** 0.09 m<sup>3</sup>

**Dimensions:** 55 x 36 x 44 cm

**Packaging:** 50 units packed in a durable export type carton suitable for sea / air freight.

**Additional Notes / Resources**

- This item is generally distributed (two per family of five persons) at the start of an emergency response.
- The condition of the jerry cans should be monitored during the response and replacement distributions should be planned after six months (or earlier if required) preferably with more durable jerry cans.
- More information may be found in the UNHCR Core Relief Items Catalogue. Item 00008879 has an updated specification and will supersede 00000096 in July 2021.

Note: last updated, April 2020

**Item Application Sample**



**General Information and Description**

Stackable 14 litre capacity, heavy duty plastic bucket with lid, handle and attached clip-on cap is a family or individual drinking water container for general household use. Made of virgin HDPE high density polyethylene and virgin LDPE low density polyethylene. Offers solution for water storage, protected from pollution with the clipped cover and cap. Easy to fill up and pour with the 50 mm opening. Stackable and easy to carry by hand with a strong flat handle on the head with a round bottom shape and a reinforcement ring. Strong and durable quality for a long-life span in tough conditions.

**Technical Specifications**

**Capacity:** 14 litres

**Weight:** Bucket min. 600 g, cover min. 150 g, handle min. 30 g.

**Material:** Food grade virgin HDPE high density polyethylene and virgin LDPE low density polyethylene.

**Dimensions:** ±5%: Height 300 mm, Top diameter: 300 mm, Bottom diameter: 240 mm.

**Manufacturing Process:** Injection moulding.

**Lid:** The bucket is supplied with a plastic lid that should be able to close tight, but is easy to open and close.

**Cover:** Clip-on plastic cover with outlet dimensions of 50 mm ±10%

**Handle:** Plastic allowing easy carrying by hand with a strong flat handle (i.e. without sharp edges) on the head with a round bottom shape and a reinforcement ring.

**Reinforced Bottom Ridge:** To prevent scraping of the base

**Reinforced Top Ridge:** To prevent deformation of the bucket circular shape.

**Curved Inside Base:** At the base of the wall to facilitate cleaning

**Colour:** White or blue (specification: Pantone Blue 300 or quadrichrome (CMYK). C = 100%, M = 45%, Y = 0%, K = 0%.)

**UNHCR Logo:** UNHCR visibility logo printed on the bucket 15cm width, 18.33cm high, placed in the centre and on the two sides of the bucket. White logo should be printed in blue buckets and blue logo should be printed in white buckets (see specification in core relief items catalogue).

**Manufacturer's Marking:** Every unit should include the manufacturer's identification moulded on the bucket at 5 cm above the bottom with letters not higher than 1.5 cm and on the opposite side of the UNHCR logo. The marking should include the manufacturer's name, unique reference batch number and date of manufacturing. No company logo should be included with the manufacturer's marking.

**Weight, Volume and Packaging**

**Gross weight:** 16 kg      **Volume:** 0.15 m<sup>3</sup>

**Dimensions:** 32 x 100 x 45 cm

**Packaging:** 20 buckets with covers and handles packed in a durable export type carton suitable for sea / air freight.

**Additional Notes / Resources**

- The lids should be put on the containers before they are distributed in the field. Beneficiaries should be advised how to use the container and specifically why the lids cannot be easily removed.
- More information may be found in the UNHCR Core Relief Items Catalogue - reference 07071.

Note: last updated, April 2020

# **SECTION TEN**

## **TOOLS**

**Item Application Sample**



**General Information and Description**

Robust, handheld, waterproof Global Positioning System (GPS) unit useful for map making, land surveying, topographic surveying, tracking, route finding, and navigation. Kit includes data cable, micro SD card, rechargeable batteries and AC charger.

**Technical Specifications**

**GPS Receiver:**

Enhanced 2.2 in 65K colour, brilliant, sunlight-readable display (176 x 220 pixels, 3.5 x 4.4 cm). Built-in 3-axis tilt-compensated electronic compass. Barometric altimeter which tracks changes in pressure to pinpoint precise altitude and plot barometric pressure over time. MicroSD™ card slot with 1.7 GB of internal memory. Supports geocaching GPX files for downloading geocaches and details straight to the unit. Stores and displays key information, including location, terrain, difficulty, hints and descriptions. Waterproof to IPX7 (submersible to 1 meter for 30 seconds). Battery (2xAA) life-time: 25 hours. Base-map included, additional maps can be added through microSD memory card or by transfer from PC. Waypoints: 2000, routes: 200, track log: 10,000 points and 200 saved tracks, automatic route calculations. Supplied with USB cable for transfer of data to/from PC, 32GB microSD card, 4 x rechargeable batteries and 2100 mAh, AC charger.

**Components Included in Kit**

**GPS Receiver:**

1 x Hand held GPS

**Accessories:**

1 x Micro SD memory card 32 GB  
1 x Mini USB PC sync cable lead for Garmin GPS units  
1 x Charger (240V AC input) for 4 AA, or 4 AAA, or 2 x 9V batteries  
4 x Rechargeable batteries (x4), 2100 mAh  
1 x Software, CD

Instruction manual in French, Spanish and English.

**Weight, Volume and Packaging**

**Gross weight:** 1.5 kg                      **Volume:** 0.02 m<sup>3</sup>

**Dimensions:** 44 x 33 x 9 cm

**Packaging:** Items packed in a sturdy tri-wall export quality carton suitable for sea / air freight.

**Additional Notes / Resources**

- The GPS unit is very useful for WASH staff to conduct activities such as determining water wells coordinates, terrain slopes, map making, topographic surveying, etc.
- Users would normally require basic training to be able to fully utilize all features of the GPS receiver.

Note: last updated, April 2020

**Item Application Sample**



**General Information and Description**

Robust, lightweight, compact, handheld, waterproof laser distometer useful for rapidly measuring distances and particularly useful to WASH staff for checking hand dug well or latrine depths with minimum safety risk.

**Technical Specifications**

**Laser Distometer:**

Laser distometer with ISO 16331-1 certified range of up to 330 ft / up to 100 m and typical measurement accuracy of 1/16" / ± 1.5 mm. Up to 10,000 measurements per set of batteries (2x AAA 1.5 V included). IP 54 protection (dust & splash protected). Memory function with area calculation (Pythagoras). Supplied with carrying case.

**Components Included in Kit**

**Laser Distometer:**

- 1 x Laser distometer, hand held
- 1 x Carrying case, black polyester fabric with belt loop
- 2 x AAA 1.5V batteries

Instruction manual in French, Spanish and English.

**Weight, Volume and Packaging**

Gross weight: 100g                      Volume: 0.01 m<sup>3</sup>

Dimensions: 12 x 4 x 3 cm

Packaging: Items packed in a sturdy tri-wall export quality carton suitable for sea / air freight.

**Additional Notes / Resources**

- The laser distometer unit is very useful for WASH staff to monitor large numbers of hand dug wells or latrines.
- Users would normally require basic training to be able to fully utilize all features of the laser distometer unit.

Note: last updated, April 2020

**Item Application Sample**



**General Information and Description**

Robust water level indicator tool for boreholes and hand dug wells with acoustic and visual signal when the sensor touches the water. Can be used for general monitoring or dynamic monitoring during pumping tests.

**Technical Specifications**

**Borehole / Well Dip Meter:**

Water level depth indicator, battery powered (4 x 1.5 V), for use in boreholes to a maximum depth of 200 metres. The water level indicator consists of a flat, two cores, heavy duty polyethylene cable calibrated in metres and centimetres on one side. A stainless steel probe is securely fastened to the free end of the cable and the cable with probe is attached to a cable winding reel. Measurements are taken by slowly lowering the cable with probe down the borehole until the probe comes in contact with the water. On contact with the water, the unit emits a high frequency audible signal, and the user can then take a depth reading from the calibrated cable. The unit is also equipped with an optical (light) signal.

**Components Included in Kit**

**Borehole / Well Dip Meter:**

- 1 x Borehole water level indicator (dip meter)
- 1 x Carrying bag, black polyester fabric
- 2 x Sets of spare batteries (e.g. 8 x AA 1.5V)

Instruction manual in French, Spanish and English.

**Weight, Volume and Packaging**

	Gross weight:	Volume:	Dimensions:
Dip Meter 100m	3 kg	0.02 m <sup>3</sup>	30 x 22 x 25 cm
Dip Meter 200m	6 kg	0.03 m <sup>3</sup>	36 x 30 x 24 cm

**Packaging:** Packed in a sturdy tri-wall export quality carton suitable for sea / air freight.

**Additional Notes / Resources**

- The borehole/well dip meter unit is an essential piece of equipment for WASH programmes undertaking new borehole/well construction, rehabilitation, or monitoring.
- Users would normally require basic training to be able to fully utilize all features of the borehole/well dip meter unit.

Note: last updated, April 2020