

NOTES :-

LEGENDS :-

REFERENCE DRAWINGS	
DRAWING No.	TITLE
A1	Plan

Aggregation Hub

NO.	DESCRIPTION OF WORK	DATE	BY	CHK.	APP.



SCALE	
DATE	
FORM NO.	1/1 0

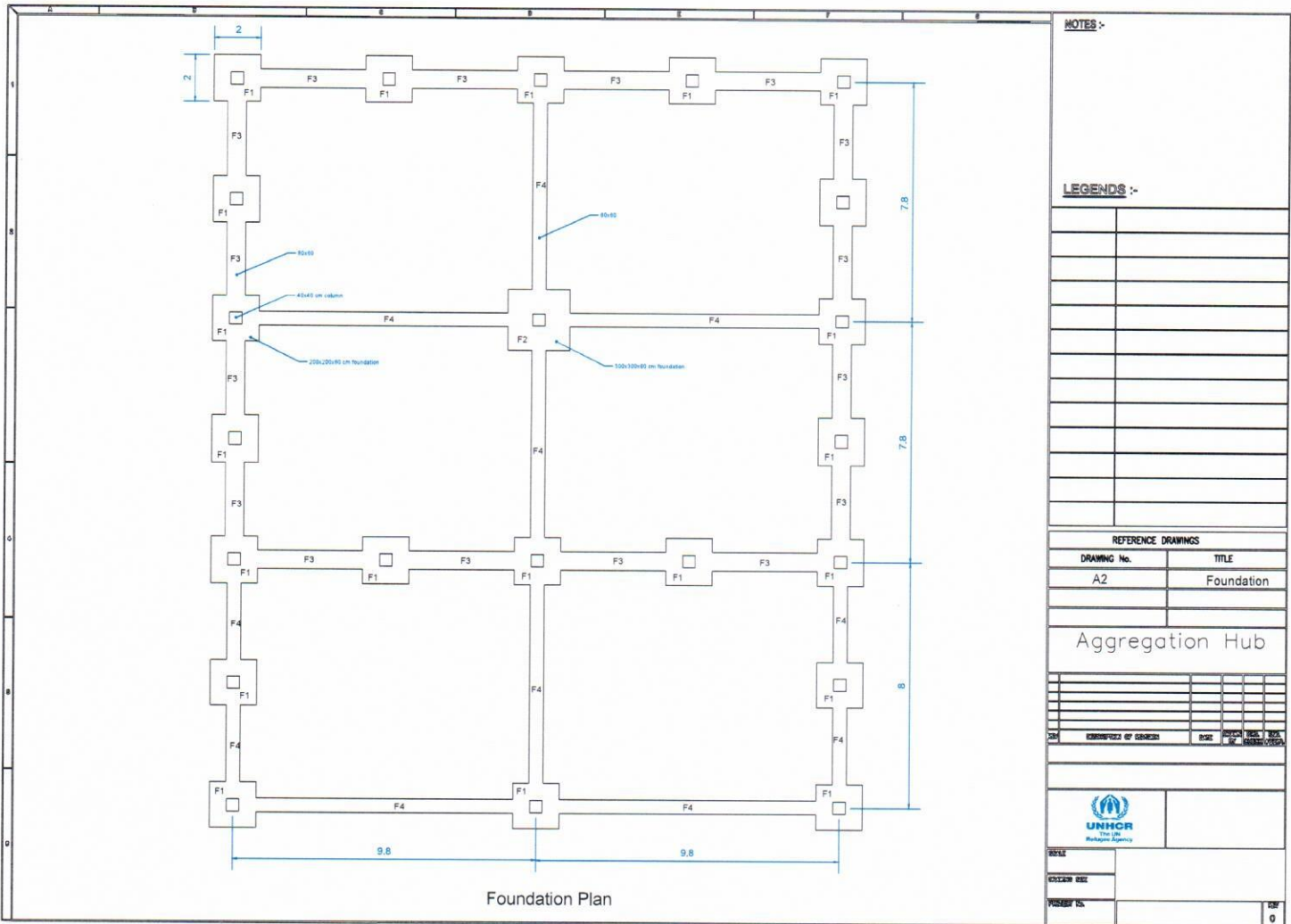

NOTES :-

LEGENDS :-

REFERENCE DRAWINGS

DRAWING No.	TITLE
A2	Foundation

Aggregation Hub

NO.	DESCRIPTION OF CHANGE	DATE	DESIGNER	CHECKED BY	APPROVED BY

UNHCR
The UN
Refugee Agency

SCALE	
ISSUED BY	
PROJECT NO.	

REV
0

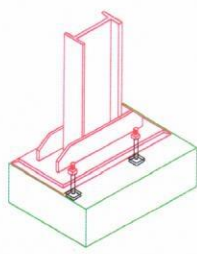
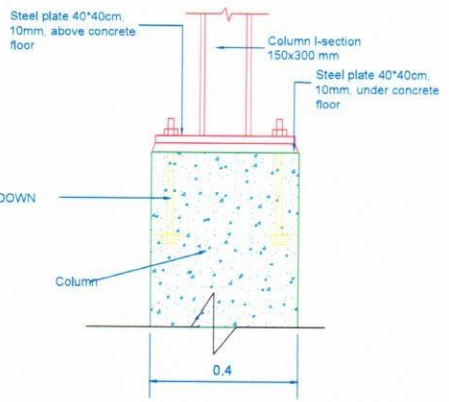

steel column and concrete column details

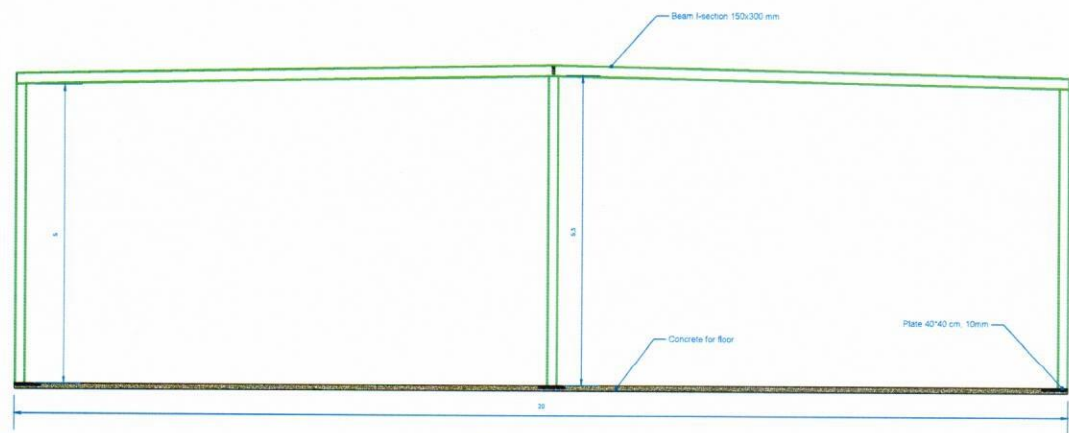

steel Structure details

NOTES :-

LEGENDS :-

SYMBOL	DESCRIPTION

REFERENCE DRAWINGS

DRAWING No.	TITLE
A3	Details

Aggregation Hub

NO.	REVISIONS BY	DATE	REASON

UNIAQIP
The A-Q
Multi-Project Agency

SCALE

ISSUED FOR

PURPOSE

0

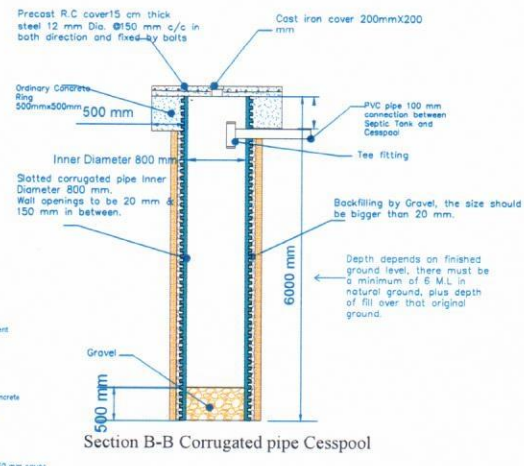
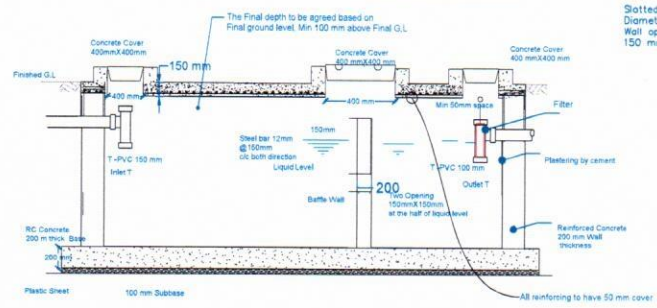
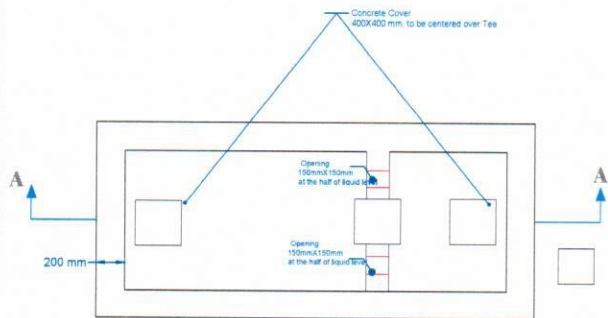
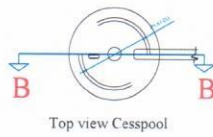

SECTION A-A

NOTES :-

LEGENDS :-

REFERENCE DRAWINGS	
DRAWING No.	TITLE
A4	Septic-Tank and cesspool

Aggregation Hub- Duhok

UNHCR
The UN Refugee Agency

ISSUE:

ISSUED BY:

PREPARED BY:

SP 0

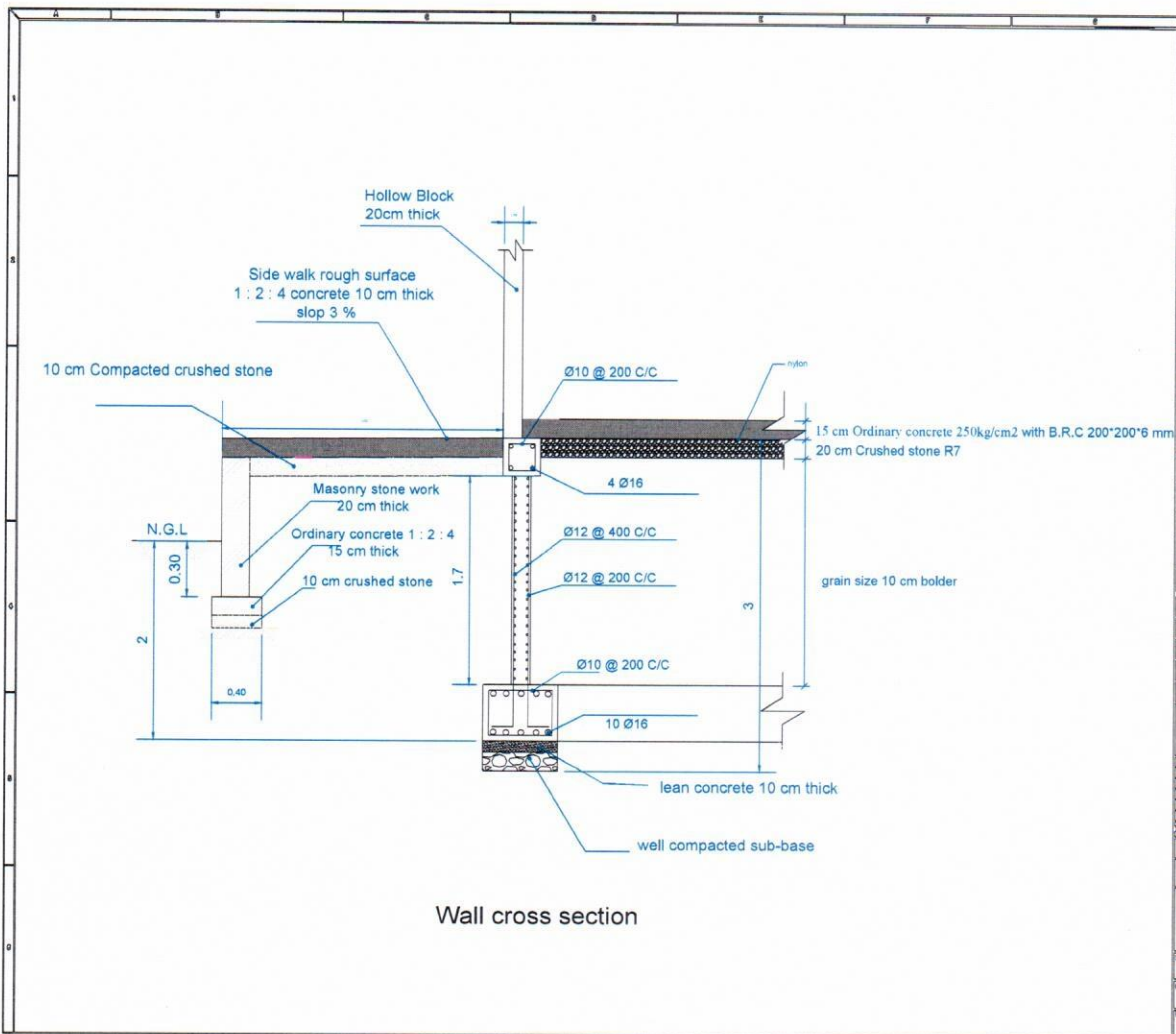

NOTES :-

LEGENDS :-

REFERENCE DRAWINGS	
DRAWING No.	TITLE
A5	Cross section
Aggregation Hub	
DATE	SCALE
DESIGNED BY	PROJECT NO.
08/0	



UNHCR
The UN
Refugee Agency

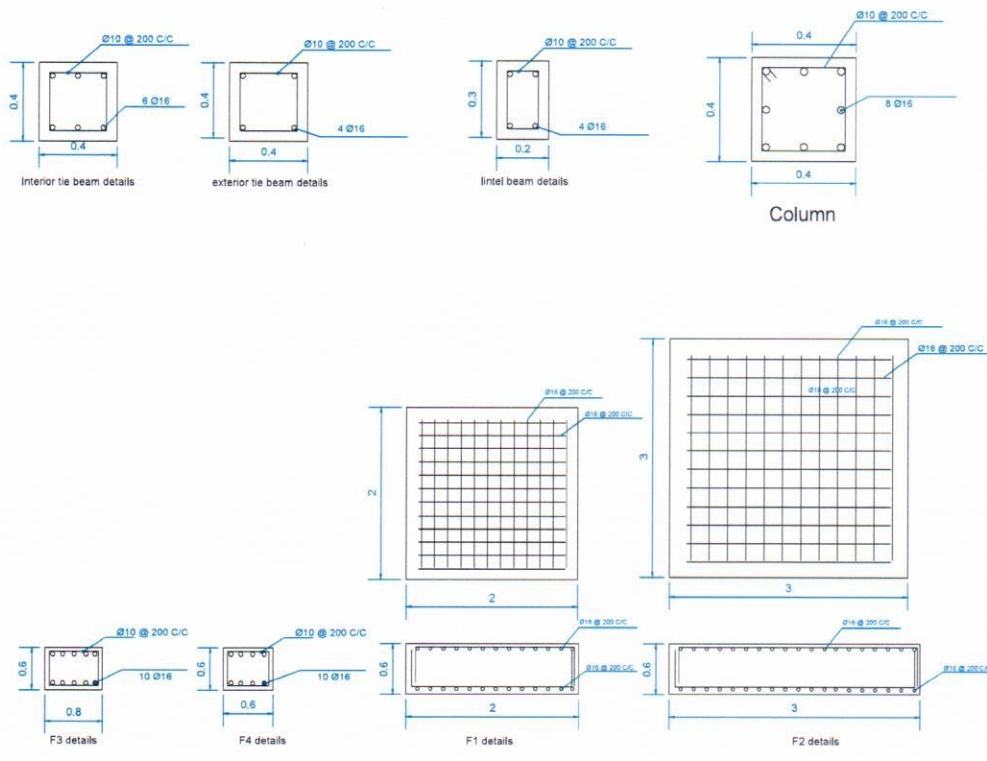

NOTES :-

LEGENDS :-

REFERENCE DRAWINGS	
DRAWING No.	TITLE
A6	Details

Aggregation Hub

DATE	DESIGNED BY	CHECKED BY	SCALE	DATE

UNHCR
The UN Refugee Agency

SCALE: 1:1

EXCEEDS PAGE: 1

PROJECT NO. 187

0